

ANGELO PO

PASTA COOKER

0G1CP1G

USE AND INSTALLATION MANUAL



AUS





**Contact for Sales or Service:
Angelo Po Catering Equipment
Unit 4, 15-17 Heatherdale Road.
Ringwood, Victoria 3134.
Telephone: (03) 9874 0440
Facsimile: (03) 9874 0330**

CONTENTS

	<i>ref. chapters</i>	<i>page</i>
1st PART	0 INFORMATION FOR THE READER	2
	1 GENERAL INFORMATION	2
	2 TECHNICAL INFORMATION	3
	3 SAFETY	5
	4 USE AND OPERATION	5
	5 SERVICING	7
2nd PART	6 FAULT	9
	7 HANDLING AND INSTALLATION.....	10
	8 ADJUSTMENTS.....	14
	9 REPLACING PARTS	15
	ANNEXES	I÷II



INDEX

- A** Adjusting burner primary air, 15
 Adjusting gas control valve minimum setting, 14
 Adjustments, recommendations for, 14
 Appliance and constructor, identification, 2
 Appliance, decommissioning, 16
 Appliance, general description, 3
 Appliance, installation, 11
 Appliance, lengthy downtimes, 7
 Appliance, testing, 13
 Appliances in banks, assembly, 11
 Assembly appliances in banks, 11
- B** Burner nozzle, replacement, 16
 Burner primary air, adjustment, 15
 Burner, primary air adjustment, 15
 Burner, switching on and off, 6
- C** Checking gas pressure, 8
 Cleaning, recommendations for, 8
 Connection, gas, 12
 Connection, water, 12
 Constructor and appliance, identification, 2
 Controls, description, 6
 Conversion of gas supply, 13
- D** Decommissioning the appliance, 16
 Description of controls, 6
 Dismantled parts, installation, 11
- F** Faults, troubleshooting, 9
- G** Gas control valve minimum setting, adjustment, 14
 Gas control valve, adjusting minimum setting, 14
 Gas pressure, checking, 8
 Gas supply, conversion, 13
 Gas tap, greasing, 15
 Gas, checking pressure, 8
 Gas, connection, 12
 General description of appliance, 3
 Greasing the gas tap, 15
- H** Handling and installation, recommendations for, 10
 Handling and lifting, 10
- I** Identification of constructor and appliance, 2
 Installation and handling, recommendations for, 10
 Installation of appliance, 11
 Installation of dismantled parts, 11
- L** Lengthy downtimes of appliance, 7
 Levelling, 11
 Lifting and handling, 10
- O** Optional accessories, 4
- P** Packaging and unpacking, 10
 Pilot light injector, replacement, 16
 Procedure for requesting service, 3
 Purpose of the manual, 2
- R** Recommendations for adjustments, 14
 Recommendations for cleaning, 8
 Recommendations for handling and installation, 10
 Recommendations for replacing parts, 15
 Recommendations for servicing, 7
 Recommendations for use, 5
 Replacement of parts, recommendations for, 15
 Replacement of the burner nozzle, 16
 Replacement of the pilot light injector, 16
- S** Safety and information signs, 4
 Safety and information, signs relating to, 4
 Safety devices, 4
 Safety regulations, 5
 Safety, devices for, 4
 Safety, regulations for, 5
 Service, procedure for requesting, 3
 Servicing, recommendations for, 7
 Switching the burner on and off, 6
- T** Technical data, 3
 Testing of the appliance, 13
 Transport, 10
 Troubleshooting, 9
- U** Unpacking and packaging, 10
 Use, recommendations for, 5
 Use, useful advice for, 7
 Useful advice for use, 7
- W** Water, connection, 12

INFORMATION FOR THE READER

0

To find the specific topics of interest to you quickly, refer to the index at the start of the manual.

This manual is subdivided into two parts.



1st part: contains all information necessary for general readers, i.e. for users of the appliance.



2nd part: contains all the information necessary for special categories of reader, i.e. all skilled operators authorised to handle, transport, install, service, repair and scrap the appliance.

While users are instructed to refer to the 1st part only, the 2nd part is addressed to skilled operators. They may also read the 1st part for a more complete picture of the information provided if necessary.

GENERAL INFORMATION

1

PURPOSE OF THE MANUAL

The constructor has produced this manual, which forms an integral part of the appliance, to provide the necessary information for those authorised to interact with it during its working life.

As well as adopting good practices for use, the manual's intended readers must read it thoroughly and apply its instructions to the letter. The constructor supplies this information in its own language (Italian), but it may be translated into other languages to meet legal and/or commercial requirements. A little time taken to read this information will allow the prevention of risks to health and safety, and the risk of economic losses.

Keep this manual in a clearly identified safe place throughout the working life of the appliance, so that it will always be available when required for consultation.

The constructor reserves the right to make changes without any obligation to provide any prior notice.

A number of symbols have been used to highlight particularly important parts of the text or important specifications. Their meaning is as defined below.



Caution - warning

Indicates that suitable procedures must be adopted to avoid putting people's health and safety at risk or causing economic losses.



Important

Indicates particularly important technical information which must not be overlooked.

CONSTRUCTOR AND APPLIANCE IDENTIFICATION

The nameplate shown here is fitted directly to the appliance.

It contains references and all essential information for operating safety.

1) Gas data

1a) Gas type

1b) Testpoint pressure

1c) Nominal gas consumption

2) Model

3) Personalization

4) Manufacturer's data

5) Serial number

6) Test gas indicator frame

7) Application

8) Country

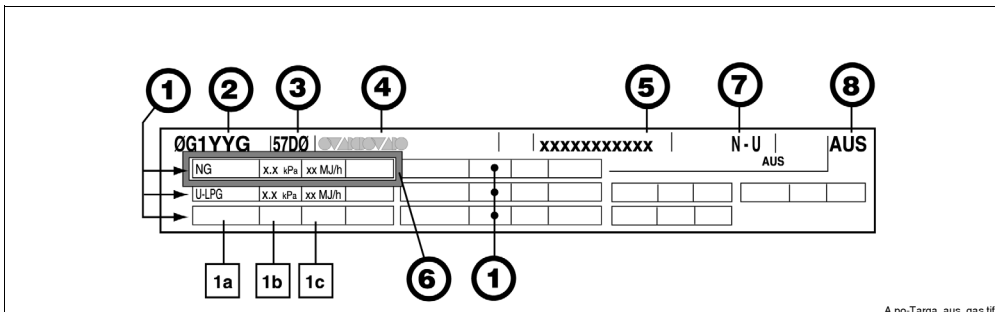

PROCEDURE FOR REQUESTING SERVICE

Contact one of the authorised service centres for all requirements.

When requesting service, state the data provide on the nameplate and provide a description of the fault.

TECHNICAL INFORMATION

2

GENERAL DESCRIPTION OF THE APPLIANCE

The pasta cooker (referred to below as the appliance) is designed and constructed to cook pasta for human consumption in water, in the professional catering sector.

Main Parts

A)Cooking well; in stainless steel.

B)Fume exhaust vent (Type A); for removal of the fumes generated by the burner.

C)Burner control knob; controls the supply of gas to the burner.

D)Adjustable water spout; directs the flow of water.

E)Piezoelectric ignition; lights the burner.

F)Water tap; regulates the flow of water.

L)Height adjustable feet; to allow perfect levelling of the appliance.

M)Gas supply connection; for connection of the gas supply.

N)Door; for access to the inside of the appliance.

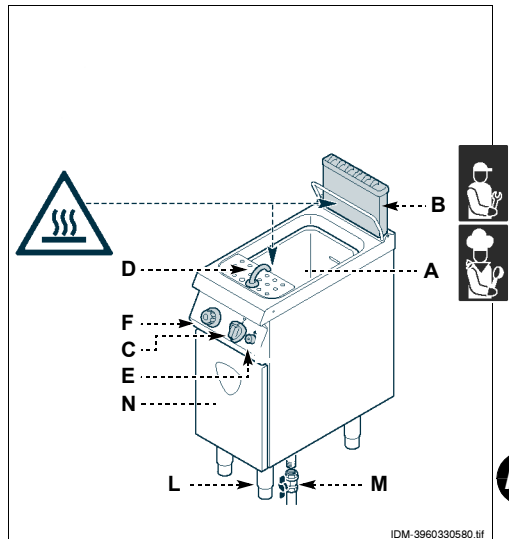

TECHNICAL DATA

See tables and "Connection chart" at the back of the manual.

AUS

IDM: 3960330580.tif

SAFETY DEVICES

Although the appliance is complete with all safety devices, during installation and connection additional devices must be added if necessary to comply with the relevant legal requirements.

The illustration shows the position of the devices.

A) Gas supply tap; for turning the connection to the gas supply line on and off.

B) Safety thermocouple; cuts out the gas supply if the flame goes out.

 **Caution - warning**
Make a daily check that the safety devices are properly installed and in good working order.

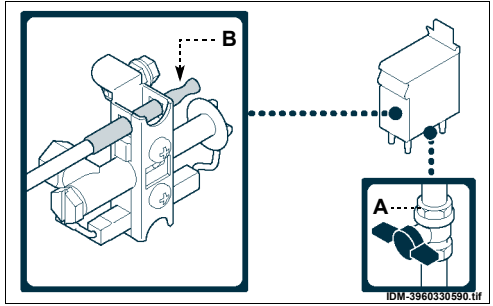

SAFETY AND INFORMATION SIGNS

The illustration shows the position of the signs provided.

A) Burn hazard: watch out for hot surfaces.

B) General hazard: read the manual carefully before carrying out any procedure.

C) General hazard: describes the precautions to be adopted during installation and commissioning.

D) General hazard: describes the precautions to be adopted during use.

E) Nameplate with manufacturer and appliance data.

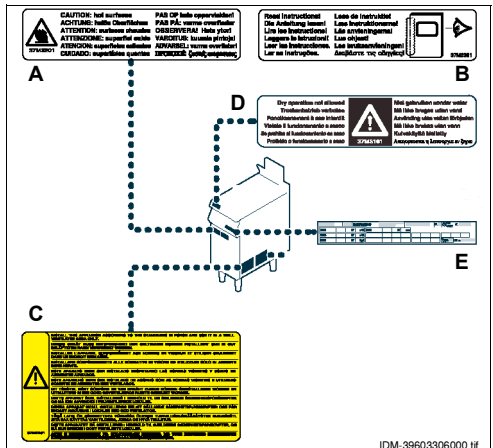

AUS

OPTIONAL ACCESSORIES

The appliance can be equipped with the following accessories on request.

A) Well lid (CV26).

B) Basket (C3011).

C) Basket (C3023).

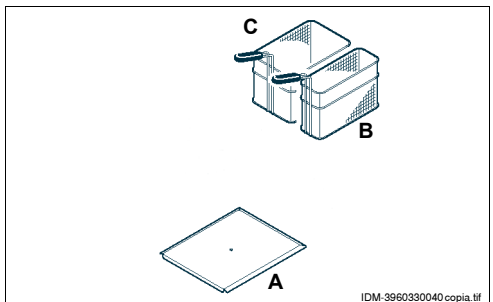

SAFETY REGULATIONS

During design and construction, the constructor has paid special attention to factors which may cause risks to the health and safety of the people interacting with the appliance. As well as complying with the relative legal requirements, he has adopted all the "rules of good construction practice". This information is provided to encourage users to take special care in order to prevent all risks. However, there is no replacement for care and attention. Safety also depends on all the operators who interact with the appliance.

Read the instructions provided in the manual supplied and those applied to the appliance itself with care, paying special attention to those relating to safety. Taking a little time to read them will prevent unpleasant accidents; it is always too late to remember what should have been done after an accident has happened.

Never tamper with, elude, eliminate or bypass the safety devices installed. Failure to comply with this rule may cause serious risks to health and safety.

Even after you have read all the appropriate documentation, if necessary on first use carry out a few trial operations to get to know the controls, especially those used for switching on and off, and their main functions.

Use the appliance only for the functions intended by the manufacturer. Improper use of the appliance may involve health and safety risks and economic losses.

All servicing operations requiring specific technical knowledge or skills must only be carried out by qualified staff with recognised experience in the specific sector.

To maintain hygiene and protect the food processed from all forms of contamination, all elements in direct or indirect contact with foodstuffs and all surrounding zones must be cleaned thoroughly. For these operations, use only food-approved detergents, and never use flammable products or products which contain substances harmful to health. Clean only when reasonably necessary and at the end of each session of use.

At the end of each session of use, make sure that the burners are off, with the control knobs turned off and the gas supply lines disconnected.



In case of lengthy downtimes, as well as disconnecting all supply lines it is also essential to clean all internal and external parts of the appliance and the surrounding environment thoroughly, complying with the constructor's instructions and the relevant legal requirements.



USE AND OPERATION

RECOMMENDATIONS FOR USE

i Important

The rate of accidents deriving from the use of appliances depends on many factors which cannot always be foreseen and controlled. Some accidents may be caused by unpredictable environmental factors, while others are due above all to the behaviour of users. As well as receiving authorisation and appropriate instruction, if necessary, the first time they use the appliance, users must carry out a few simulated practice operations in order to get to know the controls and the main functions.

Use only as intended by the constructor and never tamper with any device to obtain

performance levels outside the rated specifications.

Before use, check that the safety devices are properly installed and in good working order. As well as taking care to meet these requirements, users must also implement all safety regulations and read the description of the controls and the start-up procedure carefully.

DESCRIPTION OF CONTROLS

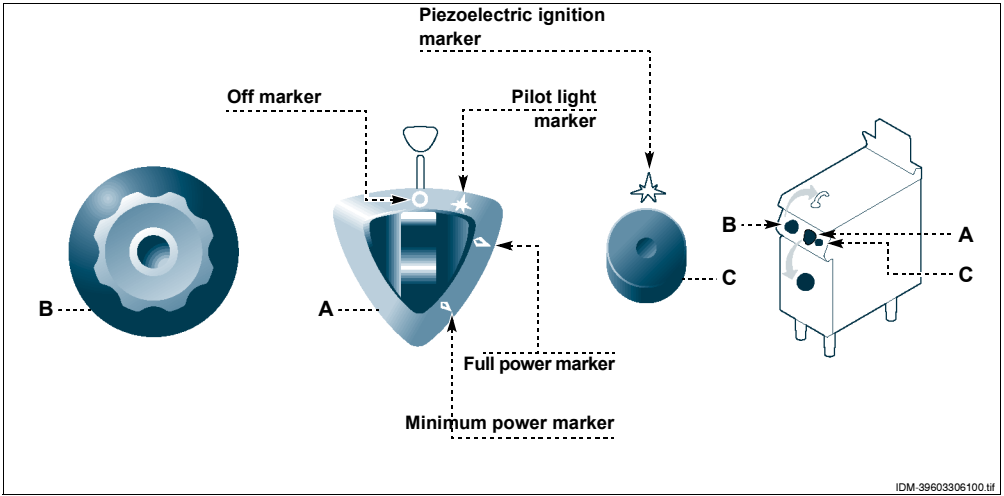

IDM-39603306100.tif



The appliance is fitted with the controls for use of its main functions.

A) Burner control knob: for lighting, turning off and regulating the relative burner and pilot

light.

B) Water tap: for regulating the flow of water.

C) Piezoelectric ignition knob: for lighting the pilot light.

SWITCHING THE BURNER ON AND OFF

The lighting and turning off procedure is as described below for both burners.

Lighting

- 1 - Turn on the gas supply tap.
- 2 - Press the knob and turn it anti-clockwise (pos. a) while at the same time pressing the piezoelectric ignition knob (A) repeatedly to light the pilot light. Keep the knob pressed for about 15 sec. to prime the thermocouple.
- 3 - Turn the knob anti-clockwise (pos. b) to light the burner.

N.B.: turn the knob gradually anti-clockwise to adjust the power of the flame down to the minimum setting.

Turning off

- 4 - Turn the knob clockwise (pos. c) to turn the burner off.
- 5 - Turn the knob clockwise (pos. d) to turn off the pilot light.
- 6 - Turn off the knob to ensure safety.

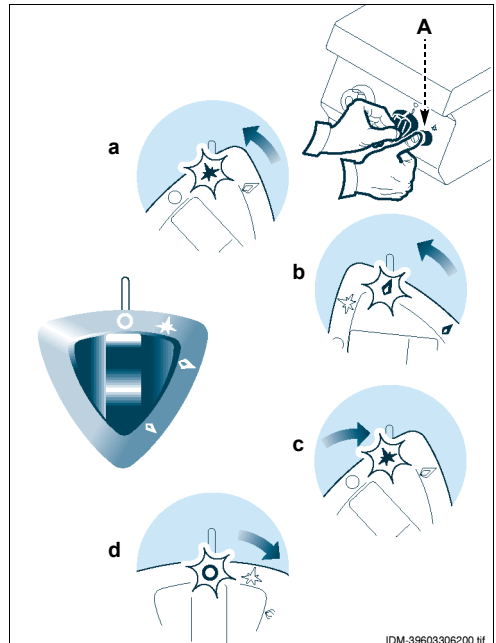

IDM-39603306200.tif

LENGTHY APPLIANCE DOWNTIMES

If the appliance is to be out of use for a lengthy period, proceed as follows:

- 1 - turn off the gas supply tap;
- 2 - clean the appliance and the surrounding areas thoroughly;

- 3 - spread a film of edible oil over the stainless steel surfaces;
- 4 - carry out all the servicing procedures;
- 5 - leave the appliance uncovered and the cooking chambers open.

USEFUL ADVICE FOR USE

To ensure correct use of the appliance, the following rules should be adopted:

- use only the accessories recommended by the constructor;
- use the baskets as appropriate;
- before filling the well, check that the drain tap (A) is turned off;
- check that the water level never drops below the minimum level marked (B);
- keep the water boiling constantly and ensure correct starch overflow drain.

 **Caution - warning**
Never use the appliance with no water in the well, as this may damage its structure.

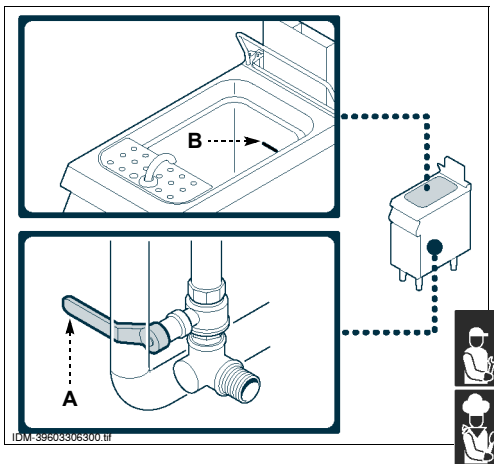

SERVICING

5

RECOMMENDATIONS FOR SERVICING

Keep the appliance at peak efficiency by carrying out the scheduled servicing procedures recommended by the constructor. Proper servicing will allow the best performance, a longer working life and constant maintenance of safety requirements.

 **Caution - warning**
Before carrying out any servicing procedure, activate all the safety devices provided and decide whether staff at work and those in the vicinity should be informed. In particular, turn off the gas supply tap and prevent access to all devices which might cause unexpected health and safety hazards if turned on.

At the end of each session of use and whenever necessary, clean:

- the well (see page 8);
- the burner (see page 8);
- the appliance and the surrounding environment (see page 8).

Every 100 working hours have skilled, authorised personnel carry out the following operations:

- a check on the gas pressure and system tightness;
- a check on the efficiency of the safety thermocouple;
- a check on the efficiency of the flues, cleaning them if necessary;
- greasing of the gas tap (see page 15).

RECOMMENDATIONS FOR CLEANING

Since the appliance is used for preparing foods for human consumption, special care must be paid to everything relating to hygiene, and the appliance and the entire surrounding environment must constantly be kept clean.



Caution - warning

Never use products containing substances harmful or hazardous for health (solvents, petroleum spirits, etc.).

Important

Before starting any cleaning operation, always turn off the gas supply tap and allow the appliance to cool.

The precautions which follow are also important.

- 1 - Clean all parts of the appliance with warm water, food-approved detergents and non-abrasive materials only.
- 2 - Rinse surfaces with drinking water and dry. Do not use pressurised water jets.
- 3 - Take special care not to damage stainless steel surfaces. In particular, avoid the use of corrosive products and do not use abrasive materials or sharp tools.
- 4 - Remove food residues immediately before they set.
- 5 - Remove the limescale deposits which may form on some of the appliance's surfaces.

CHECKING GAS PRESSURE



To carry out this operation, proceed as follows.

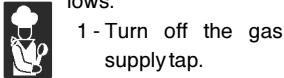

- 1 - Turn off the gas supply tap.
- 2 - Pull off the knob (A).
- 3 - Remove the knob unit (B).
- 4 - Undo the screws (C) and remove the control panel (D).
- 5 - Undo the screw (E) of the pressure connection.
- 6 - Connect the pressure gauge (F) to the pressure test point.
- 7 - Fill the well with water and turn the tap back on.
- 8 - Light the burner and turn the knob to the full flame setting (see page 6), then check that the pressure reading complies with the values in the table (see back of manual).
- 9 - Turn off the burner, disconnect the pressure gauge and restore the initial conditions after completing the operation.

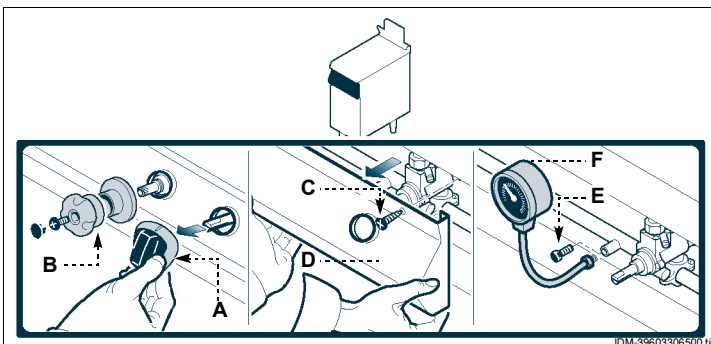

IDM:398033069500.it

AUS

TROUBLESHOOTING

The appliance has been tested before being put into service. The information provided below is intended to assist in the identification and correction of any anomalies and malfunctions which might occur during use. The user can solve some of these problems

himself, but for others specific technical knowledge or skill is required, and so they must only be carried out by qualified staff with recognised experience acquired in the specific sector of operation.

Fault	Causes	Remedies
Smell of gas.	Occasional leak because flame has gone out.	Turn off the gas supply tap and ventilate the room.
The pilot light does not ignite.	The spark ignition devices are not working.	Check that the ignition devices are in good working order. Light by hand with a naked light.
	Air in pipelines due to long period out of use.	<div style="display: flex; align-items: center;"> <div style="background-color: red; color: white; padding: 2px 5px; font-weight: bold; font-size: 0.9em;">Important</div> </div> Contact the after-sales service.
The pilot light goes out.	The thermocouple has not warmed up enough.	Make more attempts to light the flame.
The pilot light ignites but the burner remains off.		Check the condition of the thermostat and activate any ignition enabling device.
The flame is yellow.	Burner dirty, heat exchange pipes clogged, condensation drips.	Contact the after-sales service.
Burner control knob is stiff	Gas control valve malfunction.	Contact the after-sales service.



RECOMMENDATIONS FOR HANDLING AND INSTALLATION

i Important

When handling and installing the appliance comply with the information provided by the constructor directly on the packaging, on the appliance and in the instructions for use.

If necessary, the person authorised to carry out these operations must organise a "safety plan" to protect the people directly involved.

PACKAGING AND

The packaging is designed to reduce space and as appropriate to the type of transport used. To simplify transport, some components may be removed and suitably protected and packed for transport.

The packaging carries all information necessary for loading and unloading. When unpacking, check that all components are present in the correct quantities and are undamaged.



The packaging material must be properly disposed of in accordance with legal requirements.

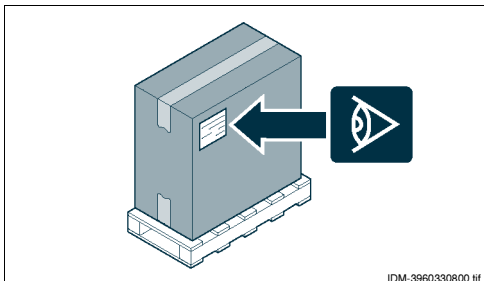

IDM-3960330800.tif

TRANSPORT

Different means of transport may be used, depending partly on the destination.

The chart shows the most commonly used alternatives.

AUS

During transport, fix the packaging to the means of transport securely to prevent undesirable shifting.

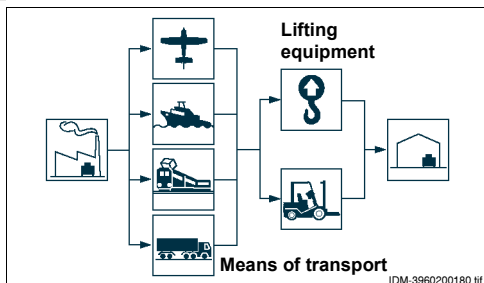

IDM-3960200180.tif

HANDLING AND LIFTING

The appliance can be handled using fork-lift or hook equipment of suitable load-carrying capacity.

Before lifting, check the position of the load's centre of gravity.

i Important

When engaging with the lifting equipment, watch out for the gas supply pipe.

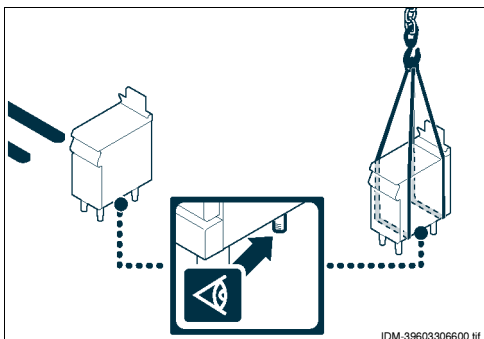

IDM-39603306600.tif

INSTALLATION OF THE APPLIANCE

All installation stages must be considered right from production of the general layout. Before starting these stages, as well as deciding the place of installation, if necessary, the person authorised to carry out these operations must organise a "safety plan" to protect the people directly involved, and he must also ensure strict compliance with all legal requirements, especially those relating to mobile work-sites.

The place of installation must have all the connections needed to supply the appliance and dispose of the production residues, must be suitably lit and must meet all legal health and hygiene requirements to prevent the contamination of the foods.

If necessary, fix the exact position of each individual appliance or subassembly by mark coordinates to locate them correctly.

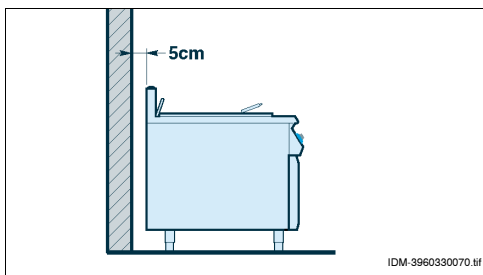

Always leave a minimum clearance of 5 cm from the rear of the appliance to the wall except if the wall, the internal structure and its coating is non-combustible. If any internal part of the wall is made from a combustible material, leave a 5 cm gap regardless of the external cladding on the wall.

INSTALLATION OF DISMANTLED PARTS

The appliance is delivered with some components dismantled and they have to be fitted during installation. Specifically, the floor-mounted feet must be fitted (A).

LEVELLING

Adjust the floor-mounted feet (A) to level the appliance.

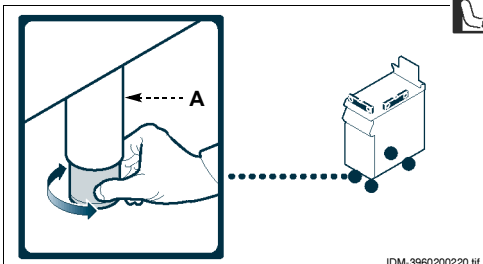

ASSEMBLING APPLIANCES IN BANKS

To assemble appliances in banks (side by side) proceed as described below.

- 1 - Remove the control panels.
- 2 - Apply masking tape to the edges to be placed side by side.
- 3 - Apply food-approved sealant to the edges to be placed side by side.
- 4 - Place the appliances alongside each other and level them (see "Levelling").
- 5 - Connect the appliances with the fixing devices.
- 6 - Remove the excess sealant and the masking tape.
- 7 - Apply the sealant to the inside of the lid (A), and fit it to cover the fixing zone.

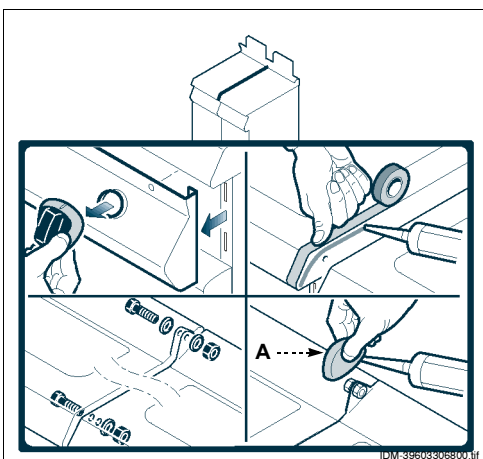

WATER CONNECTION

To make the connection, connect the mains line to the appliance's connection pipe, fitting a shut-off tap (A), to allow the water supply to be cut off when necessary.

Easily accessible filters must be fitted downstream of the tap.

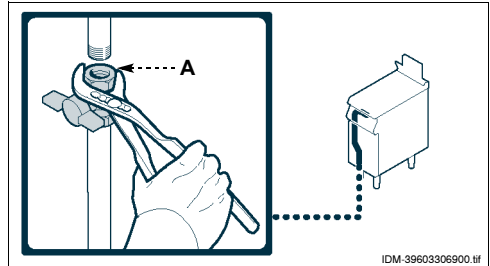

GAS CONNECTION

To make the connection, connect the mains line to the appliance's connection pipe, fitting a shut-off tap (A), to allow the gas supply to be cut off when necessary.

i Important

The tap (A), not supplied with the appliance, must be installed in an easily accessible position and its status (on or off) must be obvious at a glance.



This appliance shall be installed only by authorised personnel and in accordance with the manufacturer's installation instructions, local gas fitting regulations, municipal building codes, water supply regulations, electrical wiring regulations, AS 560/AG 601 - Gas installations and any other statutory regulations.

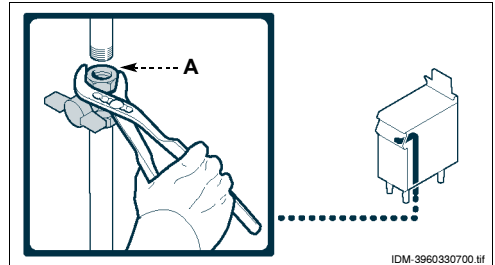

AUS Always install a quick-closing ON/OFF valve (A) (not supplied).

For natural gas equipment, fit the gas regulator (B) supplied with the appliance to gas connection.

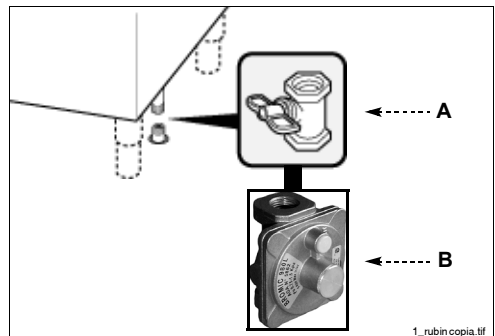

⚠ Caution - warning

For natural gas equipment this appliance must be fitted with a Bromic Oara 98 gas regulator (AGA Approval No.5862) supplied with the appliance.

Do not use any other gas regulator. Ensure regulator is fitted with respect to the gas flow marked on the housing of the regulator.

CONVERSION OF THE GAS SUPPLY

The constructor has tested the appliance with its own mains gas, identified by the sticker applied to the nameplate.

If the type of gas to be connected is different from that used for testing, proceed as follows.

- 1 - Turn off the gas supply tap (A).
- 2 - Change the burner nozzle (see page 16).
- 3 - Change the pilotlight nozzle (see page 16).
- 4 - Adjust the minimum setting on the gas control valve (see page 14).
- 5 - If necessary, adjust the burner primary air (see page 15).
- 6 - Remove the sticker from the nameplate and apply the new one to identify the gas being used.

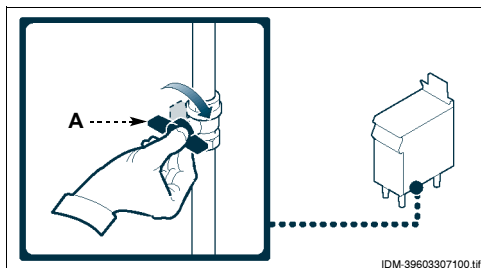

i Important

On completion of the operation, make sure that there are no gas leaks or malfunctions. If converting from Natural gas to Universal LPG make sure the Natural Gas Regulator is removed.

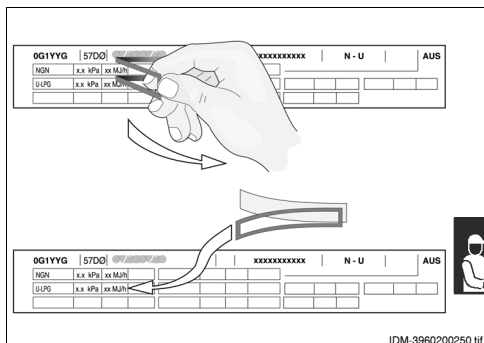

TESTING OF THE APPLIANCE

i Important

Before it is put into service, the system must be tested to check the operating conditions of every single component and identify any malfunctions. In this stage, it is important to check that all health and safety requirements have been complied with in full.

To test the system, make the following checks:

- 1 - turn on the gas supply tap and check that the connections are right;
- 2 - check that the mains gas is the same as that used for commissioning of the appliance, and carry out the conversion procedure if necessary (see page 13);
- 3 - check that the burner is switching on correctly and its combustion;

- 4 - check the gas pressure and flow-rate at minimum and maximum settings and adjust if necessary (see page 14);
- 5 - check that the safety thermocouple is working correctly;
- 6 - check that there are no gas leaks;
- 7 - check that the nameplates specify the correct gas for the country of use.

After testing, if necessary instruct the user in all the skills necessary for putting the appliance into operation in conditions of safety, in accordance with legal requirements.

RECOMMENDATIONS FOR ADJUSTMENTS

i Important

Before making any type of adjustment, activate all the safety devices provided and decide whether staff at work and those in the vicinity should be informed.

In particular, turn off the gas supply tap and prevent access to all devices which might cause unexpected health and safety hazards if turned on.

ADJUSTING GAS CONTROL VALVE MINIMUM SETTING

i Important

This adjustment is only required if the type of gas to be connected is different from that used for testing after the conversion procedure has been carried out (see page 13).

that the gas supply pressure is the same as the rated pressure for the type of gas in use (see table at back of manual).

Before making this adjustment, check



Natural gas

In this case the gas pressure upstream of the nozzle has to be adjusted; proceed as follows.

- 1 - Turn off the gas supply tap.
 - 2 - Pull off the knobs (A).
 - 3 - Remove the knob units (B).
 - 4 - Undo the screws (C) and remove the control panel (D).
 - 5 - Turn the screw to open the pressure connection (E).
 - 6 - Connect the pressure gauge (F) to the pressure test point (E).
 - 7 - Turn the gas supply tap back on.
 - 8 - Light the burner and turn the knob to the minimum flame setting.
 - 9 - Fit the minimum flow injector (G), see table pag. II Ø(3.1), screwing it fully down
 - 10 - Slowly unscrew the injector (G) until the pressure reading complies with the values in the table (see back of manual).
 - 11 - Check the stability of the flame.
- N.B.: after adjusting, seal the screw with paint.*
- 12 - Turn off the burner, disconnect the pressure gauge and restore the initial conditions after completing the operation.

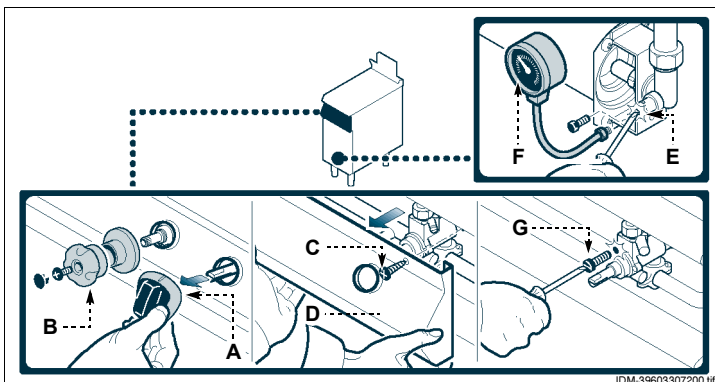

IDM-39603307200.tif

Liquid gas

To carry out this operation, proceed as follows.

- 1 - Turn off the gas supply tap.
 - 2 - Pull off the knobs (A).
 - 3 - Remove the knob units (B).
 - 4 - Undo the screws (C) and remove the control panel (D).
 - 5 - Screw the minimum flow injector fully down (G), see table pag. II Ø(3.1).
- N.B.: after adjusting, seal the screw with paint.*
- 6 - Restore the initial conditions after completing the operation.

ADJUSTING BURNER PRIMARY AIR

To carry out this operation, proceed as follows.

- 1 - Open the door (A).
- 2 - Back off the screw (B) which secures the ring nut (C).
- 3 - Set the ring nut (C) at the distance (D) shown in the table.
- 4 - Tighten the screw (B).
- 5 - Close the door (A).

Gas family	Distance (D) (mm)
Natural gas	27
Universal LPG	25

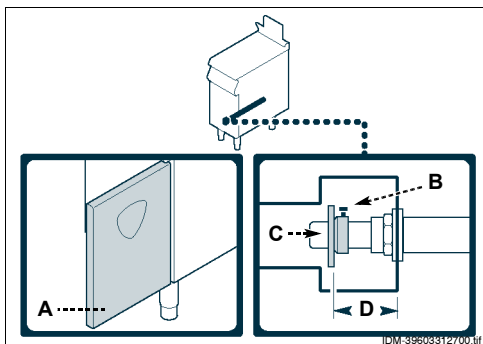

GREASING THE GAS TAP

To carry out this operation, proceed as follows.

- 1 - Turn off the gas supply tap.
- 2 - Pull off the knobs (A).
- 3 - Remove the knob units (B).
- 4 - Undo the screws (C) and remove the control panel (D).
- 5 - Undo the screws (E) and extract the cap (F).
- 6 - Pull off the cone (G).
- 7 - Clean the cone (G) and its seat.
- 8 - Coat the cone with grease (G), fit it in its seat and turn it a few times.
- 9 - Pull off the cone (G) to remove the excess grease.

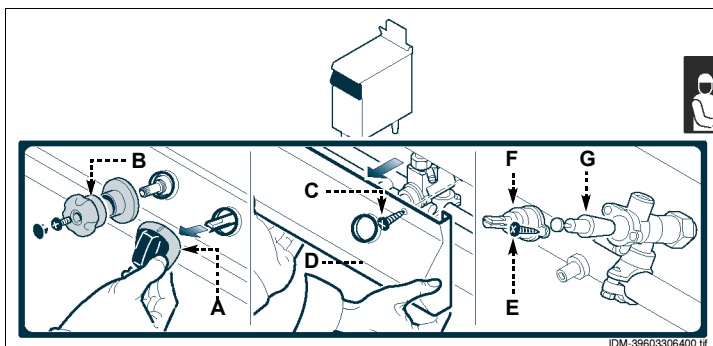

- 10 - Replace the cone (G), the cap (F), the control panel (D) and the knobs (A and B).

REPLACING PARTS

9

RECOMMENDATIONS FOR REPLACING PARTS

Before carrying out any replacement procedure, activate all the safety devices provided and decide whether staff at work and those in the vicinity should be informed. In particular, turn off the gas supply tap and prevent access to all devices which might cause unexpected health and safety hazards if turned on.

If work parts have to be replaced, use original spare parts only.

The manufacturer declines all responsibility for injury or damage to components due to the use of non original

parts, or extraordinary work on the appliance which may modify the safety requirements without the manufacturer's authorisation.

When ordering components, follow the instructions provided in the parts catalogue.

REPLACEMENT OF THE BURNER NOZZLE

To carry out this operation, proceed as follows.

- 1 - Turn off the gas supply tap.
- 2 - Open the door (A).
- 3 - Unscrew the nozzle (B) and replace it with the one suitable for the type of gas in use (see table at back of manual).
- 4 - Close the door (A).

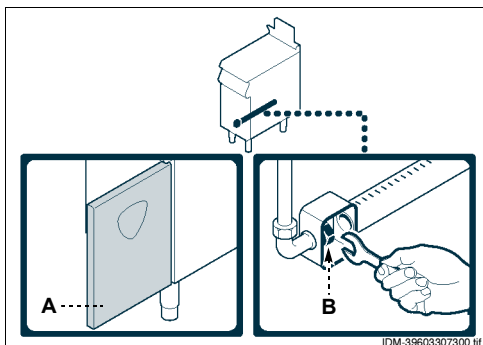

REPLACEMENT OF THE PILOT LIGHT INJECTOR

To carry out this operation, proceed as follows.

- 1 - Turn off the gas supply tap.
- 2 - Open the door (A).
- 3 - Unscrew the union (B).
- 4 - Extract the nozzle (C) and replace it with the one suitable for the type of gas in use (see table at back of manual).
- 5 - Screw the union (B) back in place and close the door (A).

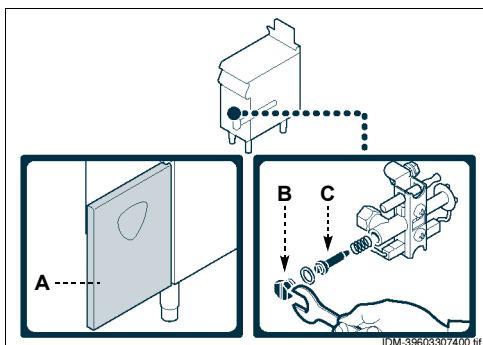

DECOMMISSIONING THE APPLIANCE

AUS

i Important

This operation must be carried out by skilled operatives in compliance with the legal requirements with regard to safety at work.

Never dump non-biodegradable materials, lubricating oils and non-metallic components (rubber, PVC, resins, etc.) in the environment. Dispose of them in accordance with the relevant legal requirements.

- ANNEXES -

Model	- Burner -	Total Gas consumption	
	40MJ/h	NGN	ULPG
0G1CP1G	N.1	40MJ/h	40MJ/h

- CONNECTION CARD -

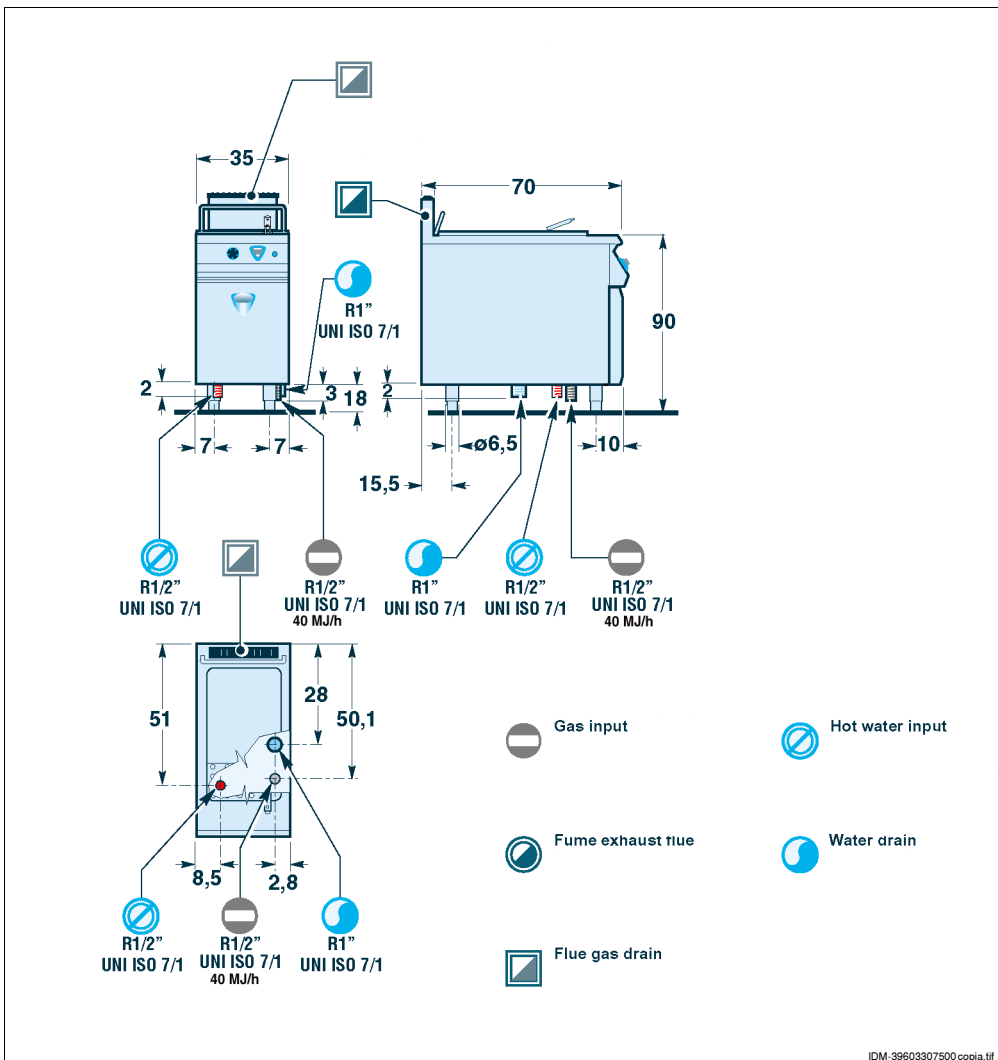

IDM: 39603307500 copia.tif

			N.G.C. (2)		T.G.C. (3)			Pilot flame	Iron Ring
GAS	TPP (1)	Supply pressure	G.C.	Ø(2.1)	G.C.	Ø(3.1)	p(3.2)	Ø(4)	Ø(5)
NGN	0.8 kPa	1.13kPa	40MJ/h	3.20 mm	20MJ/h	1.10 mm	adj-pressure 0.13kPa	0.40 mm	6holes x 5.5 mm
ULPG	2.75 kPa	2.75kPa	40MJ/h	1.70 mm	20MJ/h	1.10 mm	NO adj All screw	0.25 mm	6holes x 5.5 mm

- (1) - Test point pressure
- (2) - Nominal gas consumption
- (2.1) - Main burner injector size
- (3) - Turndown gas consumption
- (3.1) - Bypass injector size
- (3.2) - Bypass test point pressure
- (4) - Pilot injector size
- (5) - Iron Ring holes