PASTA COOKER

091CP1G

191CP2G

USE AND INSTALLATION MANUAL



English **AUS**

Ed. 0 04/2009

CONTENTS

1st PART



2nd PART



ref. chapters	page
1 GENERAL INFORMATION	2
2 TECHNICAL INFORMATION	3
3 SAFETY	6
4 USE AND OPERATION	7
5 SERVICING	10
6 FAULT	12
7 HANDLING AND INSTALLATION	13
8 ADJUSTMENTS	19
9 REPLACING PARTS	21
ANNEXES	I-V

INDEX

- A** Abnormal operation, 10
 Adjusting burner primary air (091CP1G - 191CP2G), 21
 Adjusting gas control valve minimum setting, 20
 Adjustments, recommendations for, 19
 Appliance and constructor, identification, 2
 Appliance, decommissioning, 22
 Appliance, general description, 3
 Appliance, installation, 14
 Appliance, lengthy downtimes, 9
 Appliance, testing, 19
 Appliances in banks, assembly, 15
 Assembly appliances in banks, 15
- C** Checking gas pressure, 11
 Cleaning instructions, 11
 Connection of fume exhaust vent, 17
 Constructor and appliance, identification, 2
 Controls, description, 8
 Conversion of gas supply, 18
- D** Decommissioning the appliance, 22
 Description of controls, 8
- E** Electrical connection, 17
 Environmental impact safety regulations, 6
- F** Faults, troubleshooting, 12
 Filling and emptying the well, 9
- G** Gas connection, 16
 Gas control valve minimum setting, adjustment, 20
- Gas pressure, checking, 11
 Gas supply, conversion, 18
 Gas tap, greasing, 21
 Gas, checking pressure, 11
 General description of appliance, 3
 Greasing the gas tap, 21
- H** Handling and installation, recommendations for, 13
 Handling and lifting, 13
- I** Identification of constructor and appliance, 2
 Information for the reader, 2
 Installation and handling, recommendations for, 13
 Installation of the appliance, 14
 Installing accessories, 14
 Instructions, cleaning, 11
- L** Lengthy downtimes of appliance, 9
 Levelling, 15
 Lifting and handling, 13
- O** Optional accessories, 5
- P** Packaging and unpacking, 13
 Procedure for requesting service, 3
 Purpose of the manual, 2
- R** Recommendations for adjustments, 19
 Recommendations for handling and installation, 13
 Recommendations for replacing parts, 21
- Recommendations for servicing, 10
 Recommendations for use, 7
 Replacement of parts, recommendations for, 21
 Replacement of the burner nozzle, 22
 Replacement of the pilot light injector, 22
 Room ventilation, 14
- S** Safety and information signs, 5
 Safety and information, signs relating to, 5
 Safety devices, 4
 Safety regulations, 6
 Safety, devices for, 4
 Safety, regulations for, 6
 Service, procedure for requesting, 3
 Servicing, recommendations for, 10
 Switching the burner on and off, 8
- T** Technical data, 4
 Testing of the appliance, 19
 Transport, 13
 Troubleshooting, 12
- U** Unpacking and packaging, 13
 Use, recommendations for, 7
 Use, useful advice for, 10
 Useful advice for use, 10
- W** Water connection, 16 18

AUS

Even partial reproduction of this document without the constructor's consent is forbidden.
 The constructor is committed to a policy of continuous improvement, and reserves the right to update this documentation without notice provided this does not involve safety risks.

© 2002 - Authors of texts, illustrations and paging: IDM esperti in comunicazione tecnica - Forti (Italy) - The constructor is authorised to reproduce the texts in whole or in part, provided the author is identified.

INFORMATION FOR THE READER

To find the specific topics of interest to you quickly, refer to the index at the start of the manual.

This manual is subdivided into two parts.



1st part: contains all information necessary for general readers, i.e. for users of the appliance.



2nd part: contains all the information necessary for special categories of reader, i.e. all skilled operators authorised to handle, transport, install, service, repair and scrap the appliance.

While users are instructed to refer to the 1st part only, the 2nd part is addressed to skilled operators. They may also read the 1st part for a more complete picture of the information provided if necessary.

PURPOSE OF THE MANUAL

The constructor has produced this manual, which forms an integral part of the appliance, to provide the necessary information for those authorised to interact with it during its working life.



As well as adopting good practices for use, the manual's intended readers must read it thoroughly and apply its instructions to the letter.



The constructor supplies this information in its own language (Italian), but it may be translated into other languages to meet legal and/or commercial requirements.

A little time taken to read this information will allow the prevention of risks to health and safety, and the risk of economic losses.

Keep this manual in a clearly identified safe place throughout the working life of the appliance, so that it will always be available when required for consul-

tation. The constructor reserves the right to make changes without any obligation to provide any prior notice.

A number of symbols have been used to highlight particularly important parts of the text or important specifications. Their meaning is as defined below.



Caution - warning

Indicates that suitable procedures must be adopted to avoid putting people's health and safety at risk or causing economic losses.



Important

Indicates particularly important technical information which must not be overlooked.

IDENTIFICATION OF CONSTRUCTOR AND APPLIANCE

The nameplate shown here is fitted directly to the appliance. It contains references and all essential information for operating safety.

- 1) Gas data
- 1a) Gas type

- 1b) Test point pressure
- 1c) Nominal gas consumption
- 1d) Diameter nozzle
- 2) Model
- 3) Personalisation

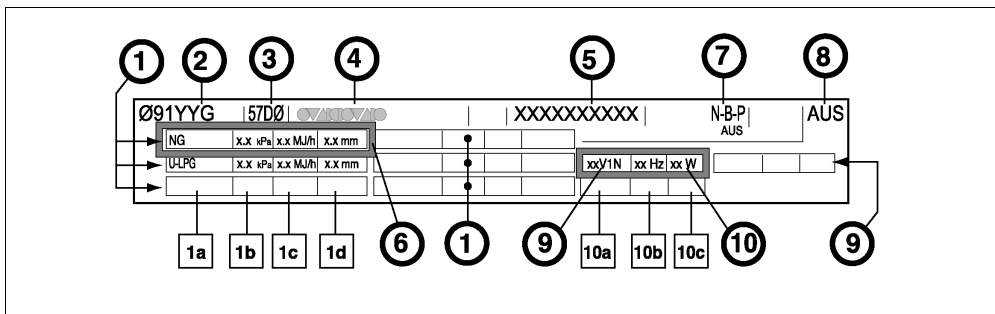

- 4) Manufacture's data
- 5) Serial number
- 6) Test gas indicator frame
- 7) Application
- 8) Country

- 9) Electrical data
- 10) Test voltage indicator frame
- 10_a) Voltage
- 10_b) Frequency
- 10_c) Power

PROCEDURE FOR REQUESTING SERVICE

Contact the authorised service centres for all requirements (see the back cover).

When requesting service, state the data provide on the nameplate and provide a description of the fault.



TECHNICAL INFORMATION

2

GENERAL DESCRIPTION OF APPLIANCE

The pasta cooker (referred to below as the appliance) is designed and constructed to cook pasta for human consumption in water, in the professional catering sector.

The appliance is produced in several versions to meet varying user requirements (see diagram).

AUS

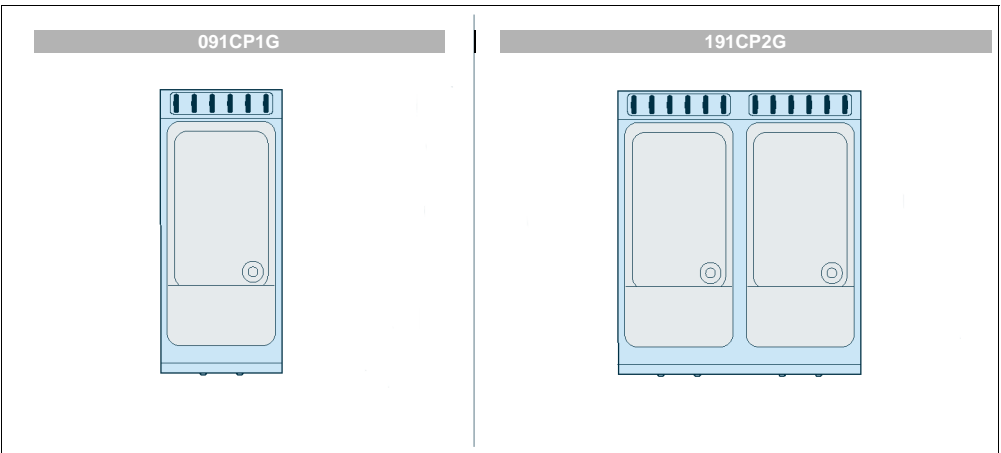

Main Parts

- A) Cooking well:** in stainless steel.
- B) Fume exhaust vent (Type A):** for removal of the fumes generated by the burner
- C) Fume exhaust vent (type B11):** removes the fumes and conveys them to a flue fitted with an extraction system serving the gas system.
- D) Fume exhaust vent (type B11):** removes the fumes and conveys them to a flue with natural draft and with draught damper device.
- E) Burner control knob:** controls the supply of gas to the burner
- F) Water control knob:** for regulating the water flow.
- G) Ignition button:** switches the burner on
- H) Mains light:** indicates that the appliance is receiving electrical power.
- L) Adjustable water spout:** directs the flow of water
- M) Hatches:** for accessing the inside of the appliance.
- N) Gas supply connection:** for connection of the gas supply.

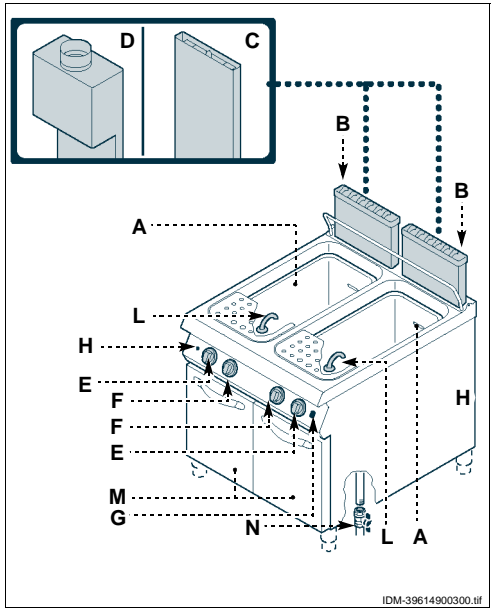

TECHNICAL DATA

See tables and "Connection chart" at the back of the manual.

AUS

SAFETY DEVICES

Although the appliance is complete with all safety devices, during installation and connection additional devices must be added if necessary to comply with the relevant legal requirements.

The illustration shows the position of the devices.

- A) Gas supply tap:** for turning the connection to the gas supply line on and off.
- B) Safety thermocouple:** cuts out the gas supply if the flame goes out.



Caution - warning

Make a daily check that the safety devices are properly installed and in good working order.

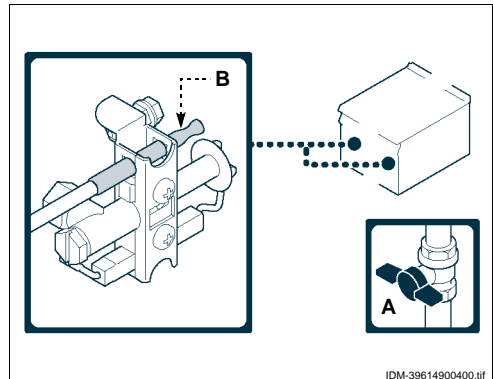

SAFETY AND INFORMATION SIGNS

The illustration shows the position of the signs provided.

A) Nameplate with manufacturer and appliance data.

B) Burn hazard: watch out for hot surfaces.

C) General hazard: when washing the appliance do not point pressurised water jets at internal parts.

D) General hazard: read the manual carefully before carrying out any procedure.

E) General hazard: dry operation is forbidden.

F) General hazard: all relevant regulations must be complied with. "Install in compliance with the relevant regulations and use in well ventilated premises only".

G) General hazard: all relevant regulations must be complied with. "No liability is accepted in case of failure to comply with the installation and commissioning instructions".

H) General hazard: drain the well completely after use.

L) Electrical hazard: danger, 240 volts; disconnect power before servicing unit.

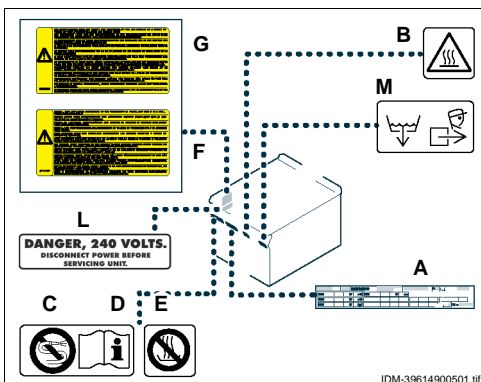

IDM-39614900501.tif



OPTIONAL ACCESSORIES

The appliance can be equipped with the following accessories on request.

A) Set of baskets KCP40

B) Basket C0909

C) Basket C2715

D) Basket C0930

E) Basket C1830

F) Basket C2830

G) Basket C4627

H) Basket C2327

L) Feet

M) Type B11 (MB33) tall fume exhaust vent.

N) Type B11 tall fume exhaust vent with draught damper device MT33

P) Well lid CV40

Q) "Bridge" installation kit (see page 15)

R) Supporting frame kit (see page 15)

S) Supporting beam kit (see page 15)

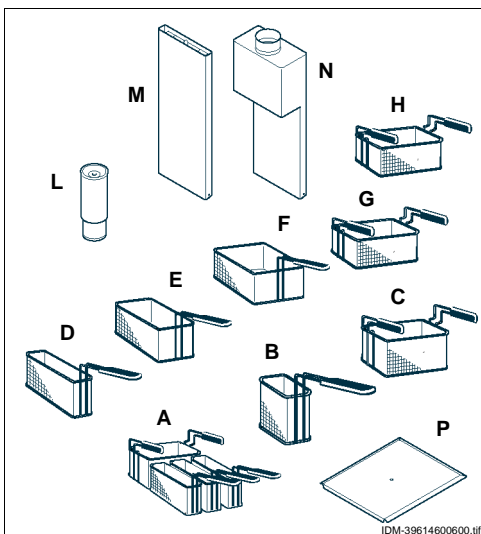

IDM-39614600600.tif

AUS

SAFETY REGULATIONS

During design and construction, the constructor has paid special attention to factors which may cause risks to the health and safety of the people interacting with the appliance. As well as complying with the relative legal requirements, he has adopted all the "rules of good construction practice". This information is provided to encourage users to take special care in order to prevent all risks. However, there is no replacement for care and attention. Safety also depends on all the operators who interact with the appliance.

Read the instructions provided in the manual supplied and those applied to the appliance itself with care, paying special attention to those relating to safety.



Never tamper with, elude, eliminate or bypass the safety devices installed. Failure to comply with this rule may cause serious risks to health and safety.



Even after you have read all the appropriate documentation, if necessary on first use carry out a few trial operations to get to know the controls, especially those used for switching on and off.

AUS Use the appliance only for the functions intended by the manufacturer. Improper use of the appliance may involve health and safety risks and economic losses.

All servicing operations requiring specific technical knowledge or skills must only be carried out by qualified staff with recognised experience in the specific sector.

To maintain hygiene and protect the food processed from all forms of contamination, all elements in direct or indirect contact with foodstuffs and all surrounding zones must be cleaned thoroughly. For these operations, use only food-approved detergents, and never use flammable products or products which contain substances harmful to health. Clean only when reasonably necessary and at the end of each session of use.

When cleaning and sanitising the appliance with detergents, wear personal protection equipment (gloves, masks, goggles, etc.) as required by the relevant health and safety legislation.

At the end of each session of use, make sure that the burners are off, with the control knobs turned off and the gas supply lines disconnected.

In case of lengthy downtimes, as well as disconnecting all supply lines it is also essential to clean all internal and external parts of the appliance and the surrounding environment thoroughly, complying with the constructor's instructions and the relevant legal requirements.

During routine use of the appliance, the Operator's constant presence is required.

When washing the appliance do not point pressurised water jets at internal parts.

Do not leave flammable objects or materials inside or close to the appliance.

**Caution - warning**

Do not spray aerosols in the vicinity of this appliance while it is in operation.

ENVIRONMENTAL IMPACT SAFETY REGULATIONS

Every organisation is obliged to apply procedures to identify and monitor the effects of its operations (products, services, etc.) on the environment.

The procedures for identifying significant environmental impacts must consider the factors listed below.

- Atmospheric emissions
- Discharge of liquid effluents
- Waste management
- Soil contamination
- Use of raw materials and natural resources
- Local problems relating to environmental impact

For this purpose, the manufacture supplies information which must be considered by all those author-

ised to interact with the appliance during its expected lifetime, in order to prevent environmental impact.

- All packaging materials must be disposed of in accordance with the relevant laws in the country of use.
- During use and maintenance, do not dump pollutants (oils, fats, etc.) in the environment; implement separate disposal as appropriate to the composition of the various materials and in compliance with the relevant laws.
- If the appliance is scrapped, sort all components by characteristics and dispose of them separately.



USE AND OPERATION

4

AUS

RECOMMENDATIONS FOR USE

Important

The rate of accidents deriving from the use of appliances depends on many factors which cannot always be foreseen and controlled. Some accidents may be caused by unpredictable environmental factors, while others are due above all to the behaviour of users. As well as receiving authorisation and appropriate instruction, if necessary, the first time they use the appliance, users must carry out a few simulated practice operations in order to get to know the controls and the main functions.

Use only as intended by the constructor and never tamper with any device to obtain performance levels outside the rated specifications. Before use, check that the safety devices are properly installed and in good working order. As well as taking care to meet these requirements, users must also implement all safety regulations and read the description of the controls and the start-up procedure carefully.

DESCRIPTION OF CONTROLS

The appliance is fitted with the controls for use of its main functions.

A) Burner control knob: for lighting, turning off and regulating the relative burner and pilot light

B) Water control knob: for filling the well in the various ways available.

C) Ignition button: lights the pilot light.

D) Mains light: indicates that the appliance is receiving electrical power.

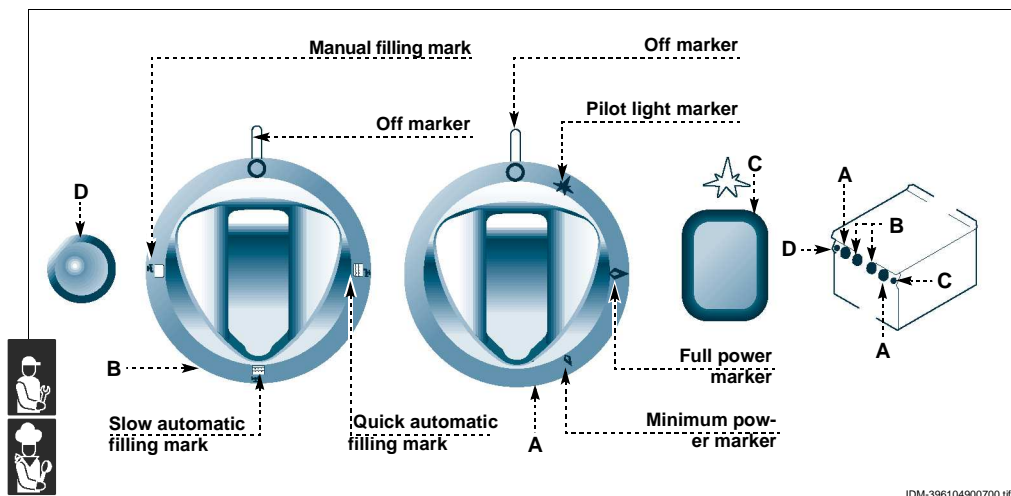

IDM-396104900700.tif

SWITCHING THE BURNER ON AND OFF

Lighting

- 1 - Turn on the gas supply tap.
- 2 - Press the knob **(A)** and turn it anti-clockwise (pos. 1), while keeping button **(B)** pressed, to light the pilot light.
- 3 - Keep the knob pressed for about 15 sec. to prime the thermocouple.
- 4 - Turn the knob **(A)** anti-clockwise (pos. 2) to light the burner.
- 5 - Turn the knob **(A)** gradually anti-clockwise to adjust the power of the flame down to the minimum setting (pos. 3).

Turning off

- 1 - Turn the knob clockwise (pos. 1) to turn the burner off. The pilot light will remain on to allow the burner to be re-lit.
- 2 - Turn the knob clockwise (pos. 4) to turn off the pilot light.
- 3 - Turn off the knob to ensure safety.

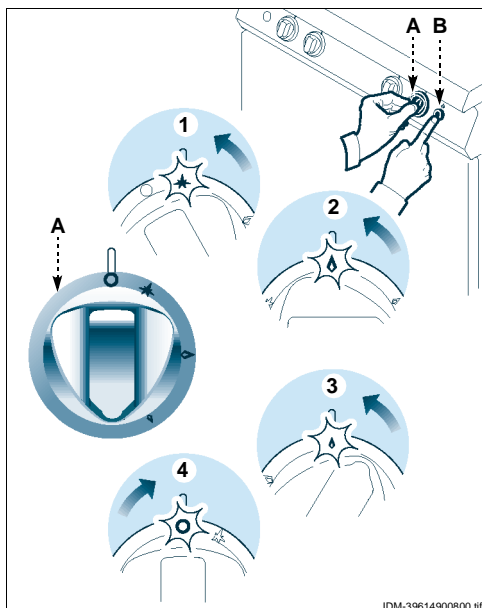

IDM-39614900800.tif

FILLING AND EMPTYING THE WELL

Filling

The well can be filled in a number of different ways.

Quick no-limits filling.

- Press and turn the knob (C) to 1 to fill the well to the level required. When the water reaches the maximum level, the burner can be lit and the different top-up modes can be enabled.

Important

After filling, the knob (C) must be turned to another position as otherwise water may overflow from the well.

Quick automatic top-up.

- Turn the knob (C) to 2 to fill the well to the maximum level automatically when the water level drops below the minimum threshold.

Slow automatic top-up.

- Turn the knob (C) to 3 for a slow, continuous flow of water that keeps the water level inside the well constant.

Important

If the water drops below the minimum level, the "quick automatic top-up" mode is automatically triggered.

Emptying

- 1 - Turn the knob (C) to 4 to shut off the water supply.
- 2 - Turn on the tap (D) to empty the well.

Important

The water drained from the appliance must pass through a suitable drain line, resistant to a temperature of at least 100°C.

The steam produced when the well is drained must not come into contact with the appliance (see also connection diagram at back of manual).

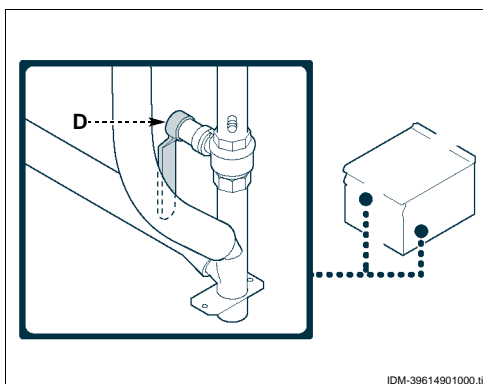
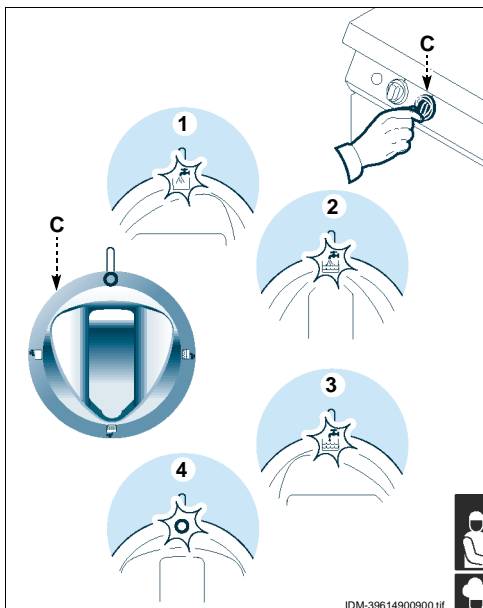

LENGTHY DOWNTIMES OF APPLIANCE

If the appliance is to be out of use for a lengthy period, proceed as follows.

- 1 - Turn off the gas supply tap.
- 2 - Clean the appliance and the surrounding areas thoroughly.
- 3 - Spread a film of edible oil over the stainless steel surfaces.

4 - Carry out all the servicing procedures.

5 - Leave the appliance uncovered and the cooking chambers open.

Important

Drain the well completely after use and clean it.

USEFUL ADVICE FOR USE

To ensure correct use of the appliance, the following rules should be adopted.

- Use only the accessories recommended by the constructor.
- Always keep the appliance and the surrounding areas clean.
- When cleaning, use only food-approved detergents.
- Use the baskets as appropriate.
- Before filling the well, check that the drain tap (A) is turned off.
- Check that the water level never drops below the minimum level marked (B).
- Keep the water boiling constantly and ensure correct starch overflow drain.

i Important

Drain the well completely after use and clean it



ABNORMAL OPERATION

⚠ Caution - warning

Never use the appliance with no water in the well, as this may damage its structure.

Any of the following are considered to be abnormal operation and may require servicing:

- Yellow tipping of the burner flame.
- Burners not igniting properly.
- Burners failing to remain alight.
- Burners extinguished by cupboard doors.

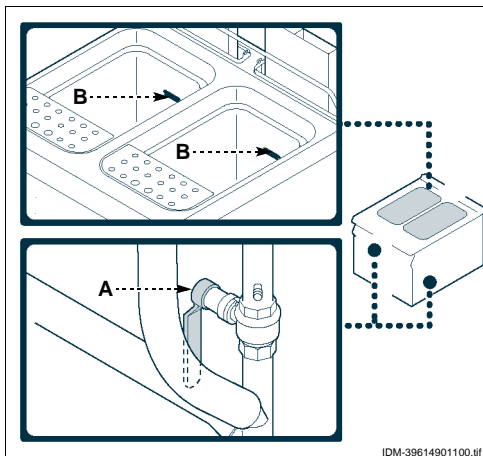

IDM-39614901100.tif

- Gas valves, which are difficult to turn.

i Important

In case the appliance fails to operate correctly, contact the authorised service provider in your area.

SERVICING

5

RECOMMENDATIONS FOR SERVICING

Keep the appliance at peak efficiency by carrying out the scheduled servicing procedures recommended by the constructor. Proper servicing will allow the best performance, a longer working life and constant maintenance of safety requirements.

⚠ Caution - warning

Servicing shall be carried out only by authorised personnel.

⚠ Caution - warning

Before carrying out any servicing procedure, activate all the safety devices provided and decide whether staff at work and those in the vicinity should be informed. In particular, turn off the gas and water supply taps, cut off the electricity supply using the master switch and prevent access to all devices that might cause unexpected health and safety hazards if turned on.

At the end of each session of use and whenever necessary, clean:

- The well
- The accessories (see page 5)
- The appliance and the surrounding environment (see page 11)

Every **100 working hours** have skilled, authorised personnel carry out the following operations.

- A check on the gas pressure and system tightness
- A check on the efficiency of the safety thermo-couple
- A check on the efficiency of the flues, cleaning them if necessary
- check that the electrical system is in good working order
- Greasing of the gas tap (see page 21)

CLEANING INSTRUCTIONS

Since the appliance is used for preparing foods for human consumption, special care must be paid to everything relating to hygiene, and the appliance and the entire surrounding environment must constantly be kept clean

i Important

Before starting any cleaning operation, always turn off the gas supply tap, cut off the electricity supply using the master switch and allow the appliance to cool.

The precautions which follow are also important.

- 1 - Clean all parts of the appliance with warm water, food-approved detergents and non-abrasive materials only.
- 2 - Thoroughly clean all parts which come into direct or indirect contact with foods and all surrounding areas.

- 3 - After use, clean the accessories with a suitable grease-remover product. If possible, wash in the dishwasher.



Caution - warning

Never use products containing substances harmful or hazardous to health (solvents, petroleum spirits, etc.).

- 4 - Rinse surfaces with drinking water and dry.
- 5 - Pressurised water jets may only be used on external parts.
- 6 - Take special care not to damage stainless steel surfaces. In particular, avoid the use of corrosive products and do not use abrasive materials or sharp tools.
- 7 - Remove food residues immediately before they set.
- 8 - Remove the limescale deposits which may form on some of the appliance's surfaces.



CHECKING GAS PRESSURE

To carry out this operation, proceed as follows.

- 1 - Turn off the gas supply tap.
- 2 - Pull off the knob **(A)**.
- 3 - Undo the screws **(B)** and remove the control panel **(C)**.
- 4 - Undo the screw **(D)** of the pressure connection.
- 5 - Connect the pressure gauge **(E)** to the pressure test point **(F)**.
- 6 - Fill the well with water and turn the gas supply tap back on.
- 7 - Light the burner and turn the knob to the full flame setting (see page 8), then check that the pressure reading complies with the values in the table (see back of manual).
- 8 - Switch off the burner, turn off the gas supply tap and disconnect the pressure gauge.
- 9 - Restore the initial conditions after completing the operation.

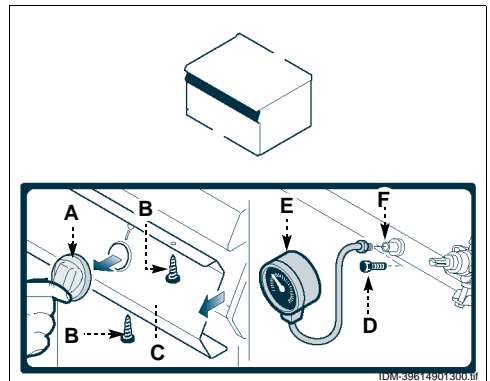

AUS

TROUBLESHOOTING

The appliance has been tested before being put into service. The information provided below is intended to assist in the identification and correction of any anomalies and malfunctions which might occur during use.

The user can solve some of these problems himself, but for others specific technical knowledge or skill is required, and so they must only be carried out by qualified staff with recognised experience acquired in the specific sector of operation.

Faults	Causes	Remedies
Smell of gas	Occasional leak because flame has gone out	Turn off the gas supply tap and ventilate the room
The pilot light does not ignite	The spark ignition devices are not working	Check that the ignition devices are in good working order. Light by hand with a naked light i Important Contact the after-sales service
	Air in pipelines due to long period out of use	Make more attempts to light the flame
The pilot light goes out	The thermocouple has not warmed up enough	Make more attempts to light the flame
The flame is yellow	Burner dirty, heat exchange pipes clogged, condensation drips	i Important Contact the after-sales service
Burner control knob is stiff	Gas control valve malfunction	i Important Contact the after-sales service
When the water control knob is turned to 2 (automatic rapid filling), water is supplied continuously, until it overflows	Blockage in pressure switch circuit.	i Important Contact the after-sales service
	Pressure switch faulty	
	Filler solenoid valve faulty	
When the water control knob is turned to 2 (automatic rapid filling), no water comes out of the tap	Pressure switch connection not made correctly	i Important Contact the after-sales service
	Water connection not made correctly	i Important Contact the after-sales service
When the water control knob is turned to 3 (automatic slow filling), slow filling does not take place	Water level maintenance solenoid valve connection not made correctly	Water level maintenance solenoid valve faulty
	Check the solenoid valve connection	i Important Contact the after-sales service



AUS

RECOMMENDATIONS FOR HANDLING AND INSTALLATION

i Important

When handling and installing the appliance comply with the information provided by the constructor directly on the packaging, on the appliance and in the instructions for

use. If necessary, the person authorised to carry out these operations must organise a "safety plan" to protect the people directly involved.

PACKAGING AND UNPACKING

The packaging is designed to reduce space and as appropriate to the type of transport used.

To simplify transport, some components may be removed and suitably protected and packed for transport.

The packaging carries all information necessary for loading and unloading.

When unpacking, check that all components are present in the correct quantities and are undamaged. The packaging material must be properly disposed of in accordance with legal requirements.

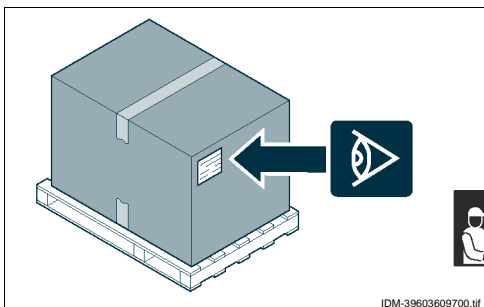

TRANSPORT

Different means of transport may be used, depending partly on the destination.

The chart shows the most commonly used alternatives.

During transport, fix the packaging to the means of transport securely to prevent undesirable shifting.

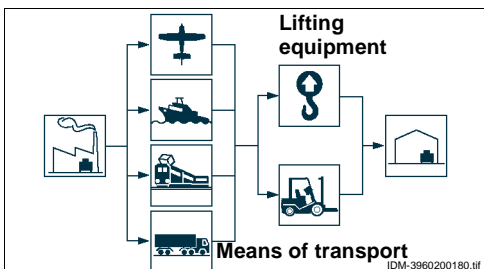

AUS

HANDLING AND LIFTING

The appliance can be handled using fork-lift or hook equipment of suitable load-carrying capacity. Before lifting, check the position of the load's centre of gravity.

i Important

When engaging with the lifting equipment, watch out for the gas supply pipe.

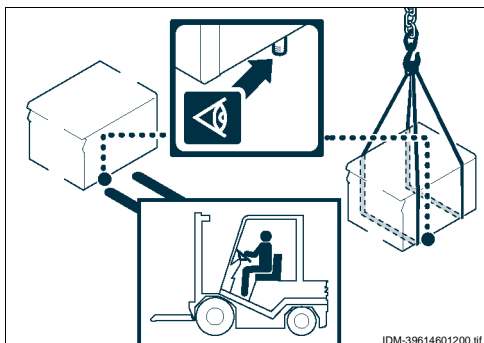

INSTALLATION OF THE APPLIANCE



Caution - warning

This appliance shall be installed only by authorised persons and in accordance with the manufacturer's installation instructions, local gas fitting regulations, municipal building codes, electrical wiring regulations, local water supply regulations, AS 5601-2004 - Gas Installations and any other statutory regulations.

All installation stages must be considered right from production of the general layout. Before starting these stages, as well as deciding the place of installation, if necessary, the person authorised to carry out these operations must organise a "safety plan" to protect the people directly involved, and he must also ensure strict compliance with all legal requirements, especially those relating to mobile work-sites.

The place of installation must have all the connections needed to supply the appliance and dispose of the production residues, must be suitably lit and must meet all legal health and hygiene require-

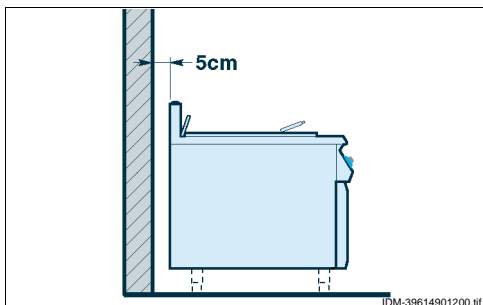

ments to prevent the contamination of the foods. If necessary, fix the exact position of each individual appliance or subassembly by mark coordinates to locate them correctly. Always leave a minimum clearance of 5cm from the rear of the appliance to the wall except if the wall, the internal structure and its coating is non-combustible. If any internal part of the wall is made from a combustible material, leave a 5cm gap regardless of the external cladding on the wall. .

ROOM VENTILATION

The room where the appliance is installed must have air inlets to ensure that the appliance can operate correctly and provide the necessary air exchange in the room itself.

The air inlets must be of appropriate size and must be protected by gratings and placed so that they cannot be obstructed.

AUS



Caution - warning

Ventilation must be in accordance with AS5601-2004 - Gas Installations. In general, the appliance should have adequate ventilation for complete combustion of gas, proper flueing and to maintain temperature of immediate surroundings within safe limits.

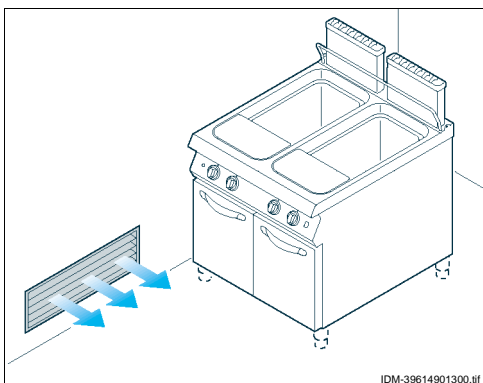

INSTALLING ACCESSORIES

Screw the feet (A) onto the structure in the connection points.

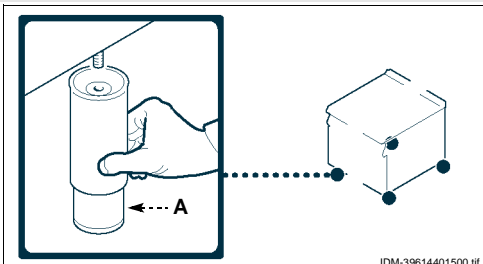

LEVELLING

Adjust the floor-mounted feet **(A)** to level the appliance.

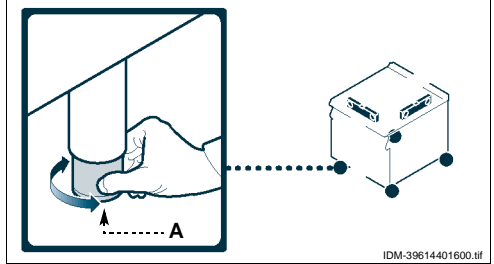

IDM-39614401600.tif

ASSEMBLY APPLIANCES IN BANKS

To assemble appliances in banks (side by side) proceed as described below.

- 1 - Pull off the knob **(A)**.
- 2 - Undo the screws **(C)** and remove the control panels **(B)**.
- 3 - Apply masking tape to the edges to be placed side by side.
- 4 - Apply food-approved sealant to the edges to be placed side by side.
- 5 - Place the appliances side by side.
- 6 - Connect the appliance using the screws and nuts **(D-E)**.
- 7 - Remove the excess sealant and the masking tape.
- 8 - Apply the sealant to the inside of the lid **(F)**, and fit it to cover the fixing zone.
- 9 - Replace the control panels **(B)** and the knobs **(A)** on completion of the operation.

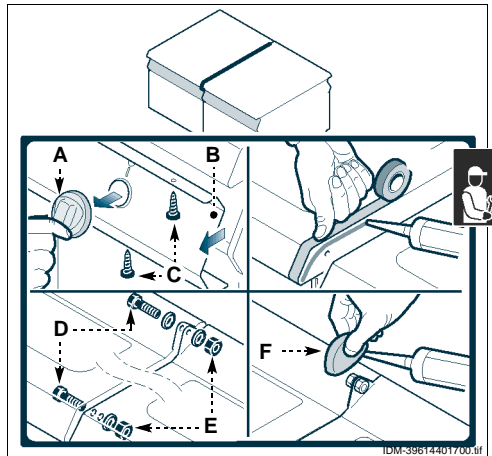

IDM-39614401700.tif

A variety of optional installation kits are available for arranging appliances in banks:

G) "Bridge" installation kit

H) Supporting frame kit

L) Supporting beam kit

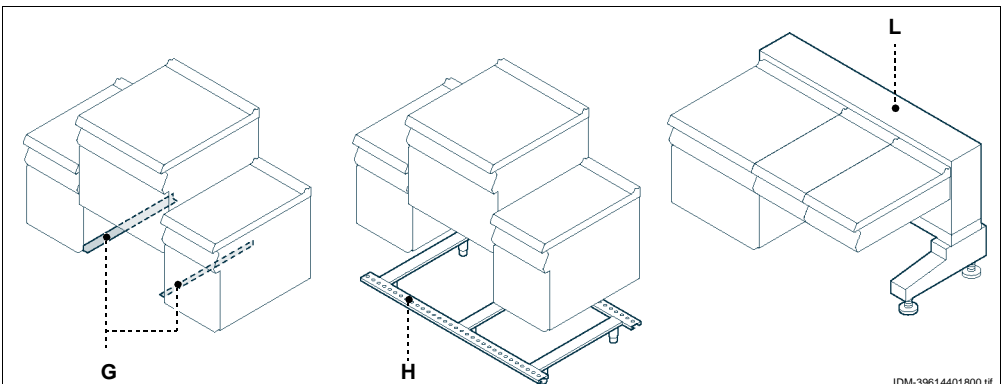

IDM-39614401800.tif

WATER CONNECTION

To make the connection, connect the mains line to the appliance's connection pipe, fitting a shut-off tap (A), to allow the water supply to be cut off when necessary. Easily accessible filters must be fitted downstream of the tap.



Caution - warning

The appliance must be supplied with drinking water having the characteristics shown in the table.

Description	Value
Pressure	150÷300 kPa (1,5÷3 bar) (*)
pH	7÷7.5
Conductivity	< 200 mS/cm
Hardness	9÷13† (5÷7‡, 6.3÷8.8‡, 90÷125 ppm)
Salt and metallic ion content	
Chlorides	< 30 mg/l
Sulphates	< 40 mg/l
Iron	< 0,1 mg/l
Copper	< 0.05 mg/l
Manganese	< 0,05 mg/l



(*) If the intake pressure exceeds 3 bar fit a pressure reducer.

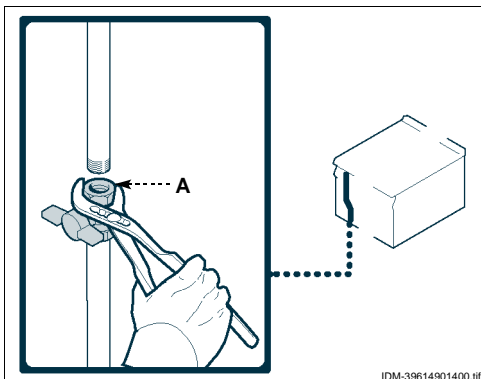

IDM-39614901400.tif

GAS CONNECTION

To make the connection, connect the mains line to the appliance's connection pipe, fitting a shut-off tap (A), to allow the gas supply to be cut off when necessary.



Important

The tap (A), not supplied with the appliance, must be installed in an easily accessible position and its status (on or off) must be obvious at a glance.

This appliance shall be installed only by authorised personnel and in accordance with the manufacturer's installation instructions, local gas fitting regulation municipal building codes, water supply regulations, electrical wiring regulations, AS 5601/AG 601 - Gas Installations and any other statutory regulations.

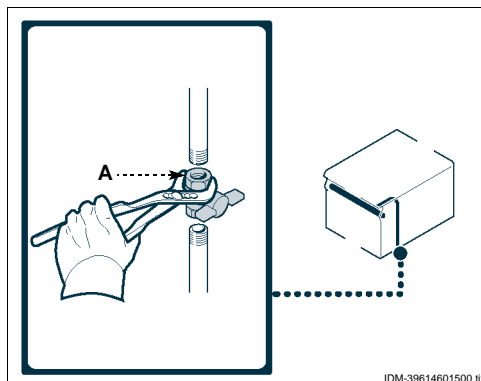

IDM-39614601500.tif

CONNECTION OF FUME EXHAUST VENT

i Important

Make the connection in compliance with the relevant legal requirements, using appropriate and recommended materials.

Connecting to a flue with natural draught

To carry out this operation, proceed as follows.

- 1 - Connect the appliance's exhaust outlet to the flue (A) using a line complying with the dimensions shown in the diagram.

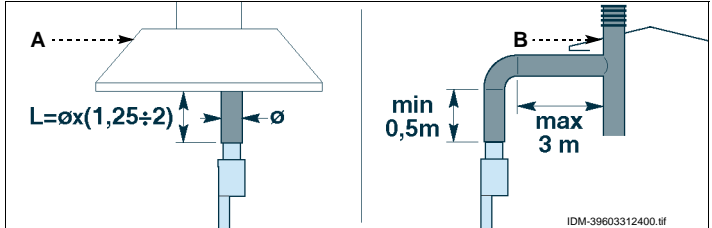

Connecting to a fan extractor hood

To carry out this operation, proceed as follows.

- 2 - Position the appliance underneath the hood (B) and connect a line of the dimensions shown in the diagram to the appliance's exhaust outlet.

i Important

The fan of the extraction system must switch on automatically when the gas supply tap is turned on.



ELECTRICAL CONNECTION

i Important

The connection must be made by authorised, skilled personnel, in accordance with the relevant legal requirements, using appropriate and specified materials.

The appliance is supplied with operating voltage 230V/1N.

⚠ Caution - warning

Before doing any work, cut off the mains electricity supply.

Connect the appliance to the mains electricity supply as follows.

- 1 - If not already present, install a circuit-breaker (A) with overload cutout and differential safety breaker close to the appliance.

AUS

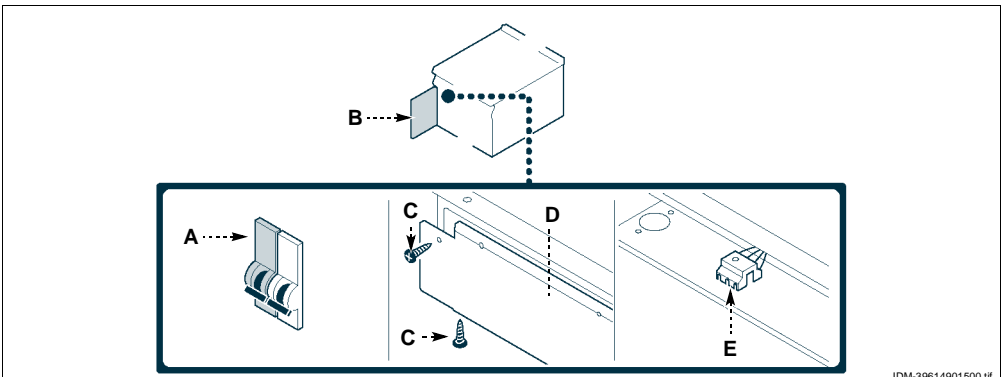

- 2 - Open the hatch (B).
- 3 - Undo the screws (C) to remove the guard (D).
- 4 - Connect the circuit-breaker (A) to the terminal board (E) of the appliance as shown in the diagram and in the electrical system diagram at the back of the manual. Use a cable with at least H05RN-F characteristics.

i Important

When connecting, take care over the connection of the neutral and earth wires; if they are not connected correctly, the burner does not light.

- 5 - Replace the guard (D).
- 6 - Close the door (B) when the operation is complete.

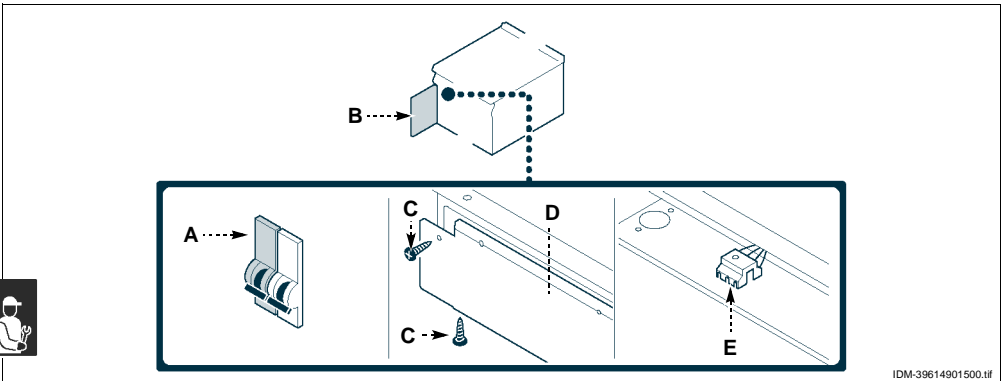

CONVERSION OF GAS SUPPLY

Always install a quick-closing ON/OFF valve (A) (not supplied). For Natural gas equipment, fit the gas regulator (B) supplied with appliance to gas connection.



Caution - warning

This appliance must be fitted with a Bromic Oara 980L gas regulator for Natural Gas or a Bromic 986L gas regulator for U-LPG (AGA Approval No.5862) supplied with the appliance. Do not use any other gas regulator.

Ensure regulator is fitted with respect to the gas flow marked on the housing of the regulator.

The constructor has tested the appliance with its own mains gas, identified by the sticker applied to the nameplate.

If the type of gas to be connected is different from that used for testing, proceed as follows.

- 1 - Turn off the gas supply tap (A).
- 2 - Change the burner nozzle (see page 22).
- 3 - Change the pilot light nozzle (see page 22).
- 4 - Adjust the minimum settings of the gas control valves of the burners (see page 20).
- 5 - If necessary, adjust the burner primary air (see page 21).

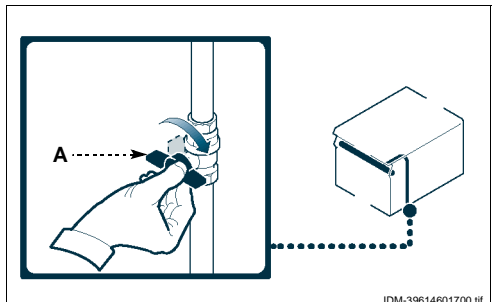
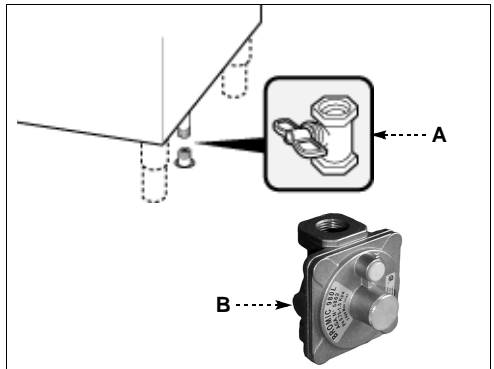

- Remove the sticker from the nameplate and apply the new one to identify the gas being used.

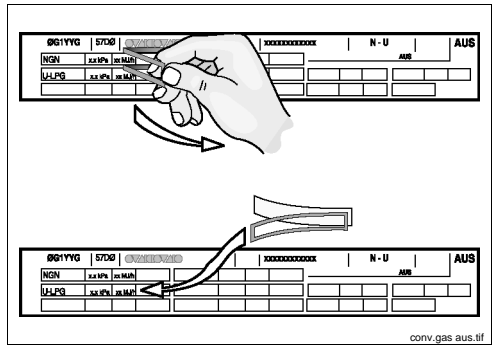

i Important

On completion of the operation, make sure that there are no gas leaks or malfunctions. If converting from Natural Gas to Universal LPG make sure the natural gas regulator is removed and replaced with the U-LPG Regulator and primary air adjustment is locked with Loctite to prevent adjustment.

TESTING OF THE APPLIANCE

i Important

Before it is put into service, the system must be tested to check the operating conditions of every single component and identify any malfunctions. In this stage, it is important to check that all health and safety requirements have been complied with in full.

To test the system, make the following checks.

- Turn on the gas supply tap and check that the connections are right.
- Check that the mains gas is the same as that used for commissioning of the appliance, and carry out the conversion procedure if necessary (see page 18).
- Check that the burner is switching on correctly and its combustion.

- Check the gas pressure and flow-rate at minimum and maximum settings and adjust if necessary (see page 11).
- Check that the safety thermocouple is working correctly.
- Check that there are no gas leaks.
- Check that the nameplates specify the correct gas for the country of use.



⚠ Caution - warning

In case the appliance fails to operate correctly after all checks have been carried out, refer to the authorised service provider in your area

After testing, if necessary instruct the user in all the skills necessary for putting the appliance into operation in conditions of safety, in accordance with legal requirements.

AUS

ADJUSTMENTS

8

RECOMMENDATIONS FOR ADJUSTMENTS

⚠ Caution - warning

Servicing shall be carried out only by authorised personnel.

i Important

Before making any type of adjustment, activate all the safety devices provided and decide whether staff at work and those in the vicinity should be informed. In particular, turn off the gas supply tap and prevent access to all devices which might cause unexpected health and safety hazards if turned on.

i Important

This adjustment is only required if the type of gas to be connected is different from that used for testing after the conversion procedure has been carried out (see page 18). Before making this adjustment, check that the gas supply pressure is the same as the rated pressure for the type of gas in use (see table at back of manual).

Natural gas

Proceed as follows.

- 1 - Turn off the gas supply tap.
- 2 - Pull off the knob **(A)**.
- 3 - Undo the screws **(B)** and remove the control panel **(C)**.
- 4 - Undo the screw **(D)** of the pressure connection.
- 5 - Connect the pressure gauge **(E)** to the pressure test point **(F)**.
- 6 - Turn the gas supply tap back on.
- 7 - Light the burner and turn the knob to the minimum flame setting.
- 8 - Remove the minimum flame injector **(G)** and replace it with the one suitable for the type of gas in use (see table at back of manual), screwing it fully down.
- 9 - Slowly unscrew the injector **(G)** until the pressure reading complies with the values in the table (see back of manual).
- 10 - Check the stability of the flame.
- 11 - After making the setting, seal the screw with paint.
- 12 - Switch off the burner, turn off the gas supply tap and disconnect the pressure gauge.
- 13 - Replace the control panel **(C)** and the knobs **(A)** on completion of the operation.

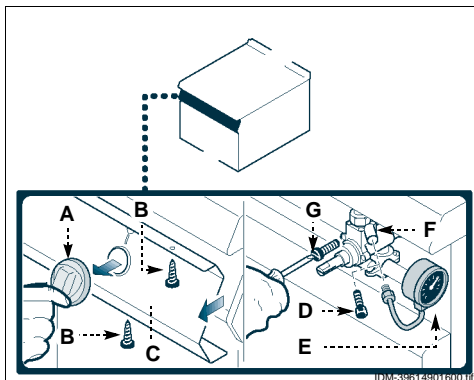

Liquid gas

To carry out this operation, proceed as follows.

- 1 - Turn off the gas supply tap.
- 2 - Pull off the knob **(A)**.
- 3 - Undo the screws **(B)** and remove the control panel **(C)**.
- 4 - Remove the minimum flame injector **(G)** and replace it with the one suitable for the type of gas in use (see table at back of manual), screwing it fully down.
- 5 - After making the setting, seal the screw with paint.
- 6 - Replace the control panel **(C)** and the knobs **(A)** on completion of the operation.



AUS

ADJUSTING BURNER PRIMARY AIR (091CP1G - 191CP2G)

To carry out this operation, proceed as follows.

- 1 - Turn off the gas supply tap.
- 2 - Open the hatch (A).
- 3 - Back off the screw (B) which secures the ring nut (C).
- 4 - Set the ring nut (C) at the distance (D) shown in the table.
- 5 - Tighten the screw (B).
- 6 - After making the setting, seal the screw with paint.
- 7 - Close the door (A) when the operation is complete.

Gas family	Distance (D) (mm)
Natural gas	26 ⁺⁰ ₋₁
Universal LPG	21 ⁺⁰ ₋₁

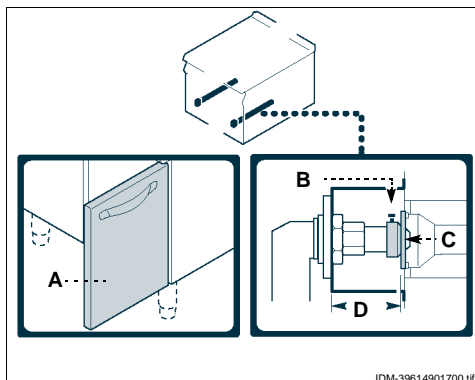

IDM-39614901700.tif

GREASING THE GAS TAP

To carry out this operation, proceed as follows.

- 1 - Turn off the gas supply tap.
- 2 - Pull off the knob (A).
- 3 - Undo the screws (B) and remove the control panel (C).
- 4 - Undo the screws (D) and extract the cap (E).
- 5 - Pull off the cone (F).
- 6 - Clean the cone (F) and its seat.
- 7 - Coat the cone with grease (F), fit it in its seat and turn it a few times.
- 8 - Pull off the cone (F) to remove the excess grease.
- 9 - Replace the cone (F) and the cap (E).
- 10 - Replace the control panel (C) and the knobs (A) on completion of the operation.

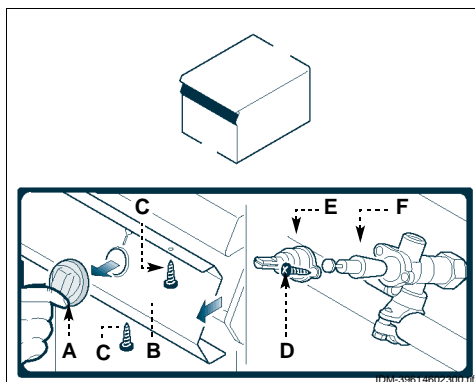

IDM-39614602300.tif



AUS

REPLACING PARTS

9

RECOMMENDATIONS FOR REPLACING PARTS

Before carrying out any replacement procedure, activate all the safety devices provided and decide whether staff at work and those in the vicinity should be informed. In particular, turn off the gas supply tap and prevent access to all devices which might cause unexpected health and safety hazards if turned on. If work parts have to be replaced, use original spare parts only.

The manufacturer declines all responsibility for injury or damage to components due to the use of non original parts, or extraordinary work on the appliance which may modify the safety requirements without the manufacturer's authorisation.

When ordering components, follow the instructions provided in the parts catalogue (to obtain spare parts see back cover).

REPLACEMENT OF THE BURNER NOZZLE

To carry out this operation, proceed as follows.

- 1 - Turn off the gas supply tap.
- 2 - Open the hatch (A).
- 3 - Unscrew the nozzle (B) and replace it with the one suitable for the type of gas in use (see table at back of manual).
- 4 - Close the door (A) when the operation is complete.

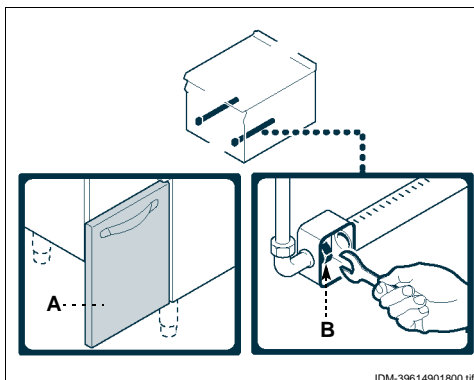

IDM-39614901800.tif



REPLACEMENT OF THE PILOT LIGHT INJECTOR

To carry out this operation, proceed as follows.

- 1 - Turn off the gas supply tap.
- 2 - Open the hatch (A).
- 3 - Unscrew the union (B).
- 4 - Remove the nozzle (C) and replace it with the one suitable for the type of gas in use (see table at back of manual).
- 5 - Screw the union (B) back into place and close the door (A) on completion of the operation.

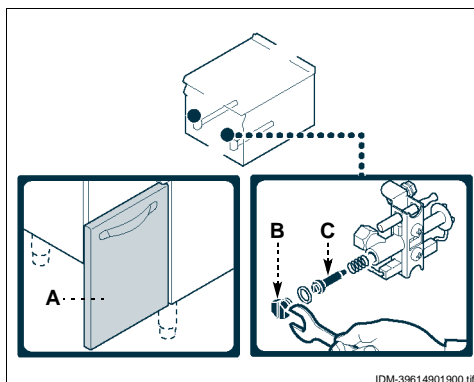

IDM-39614901900.tif

DECOMMISSIONING THE APPLIANCE

i Important

This operation must be carried out by skilled operatives in compliance with the legal requirements with regard to safety at work.

Never dump non-biodegradable materials, lubricating oils and non-metallic components (rubber, PVC, resins, etc.) in the environment. Dispose of them in accordance with the relevant legal requirements.

ANNEXES

Model	Well	Burner	Total Gas consumption		Electrical connection
		56 MJ/h	NGN	ULPG	
091CP1G	N. 1 (40 l)	N. 1	56 MJ/h	56 MJ/h	2W/240V1~N 50 Hz

CONNECTION CARD (091CP1G)

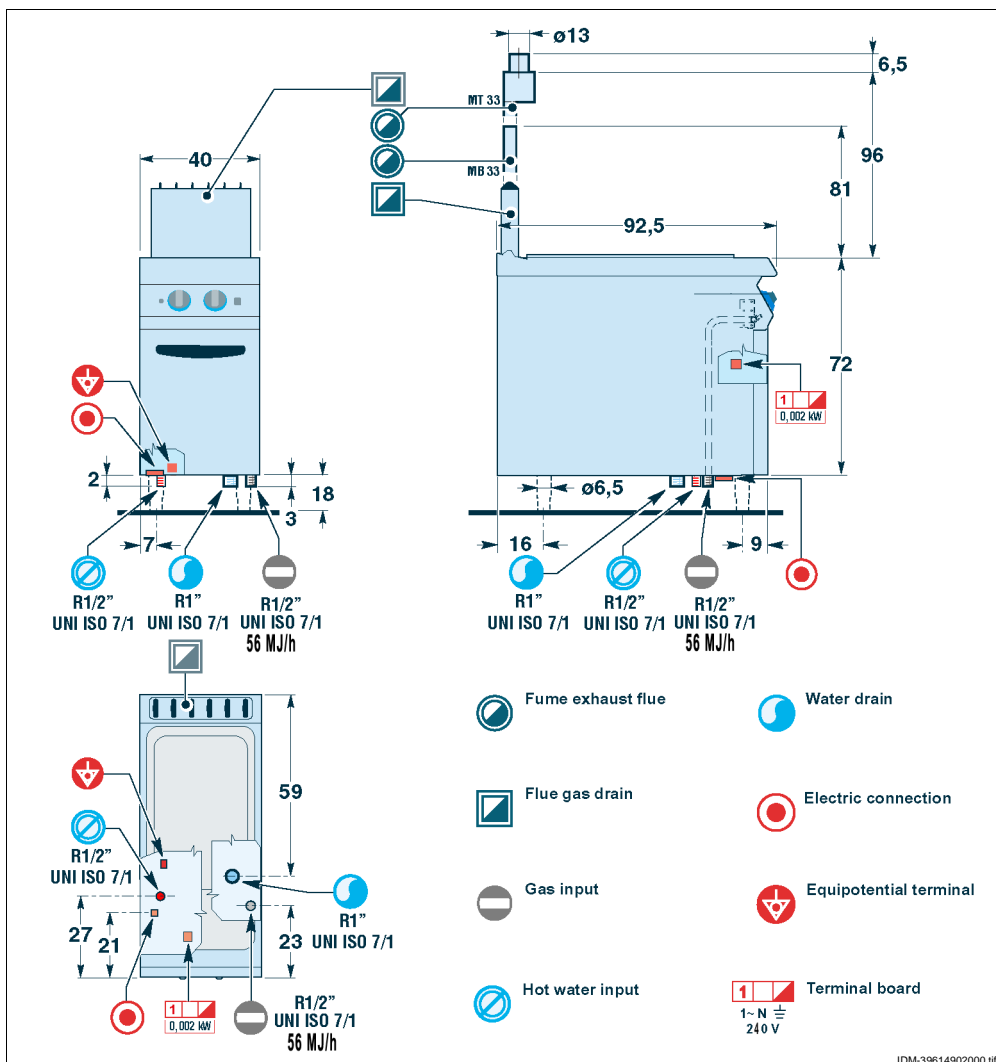

Model	Well	Burner	Total Gas consumption		Electrical connection
		56 MJ / h	NGN	ULPG	
191CP2G	N. 2 (40 l)	N. 2	112 MJ / h	112 MJ / h	2W/240V1~N 50 Hz

CONNECTION CARD (191CP2G)

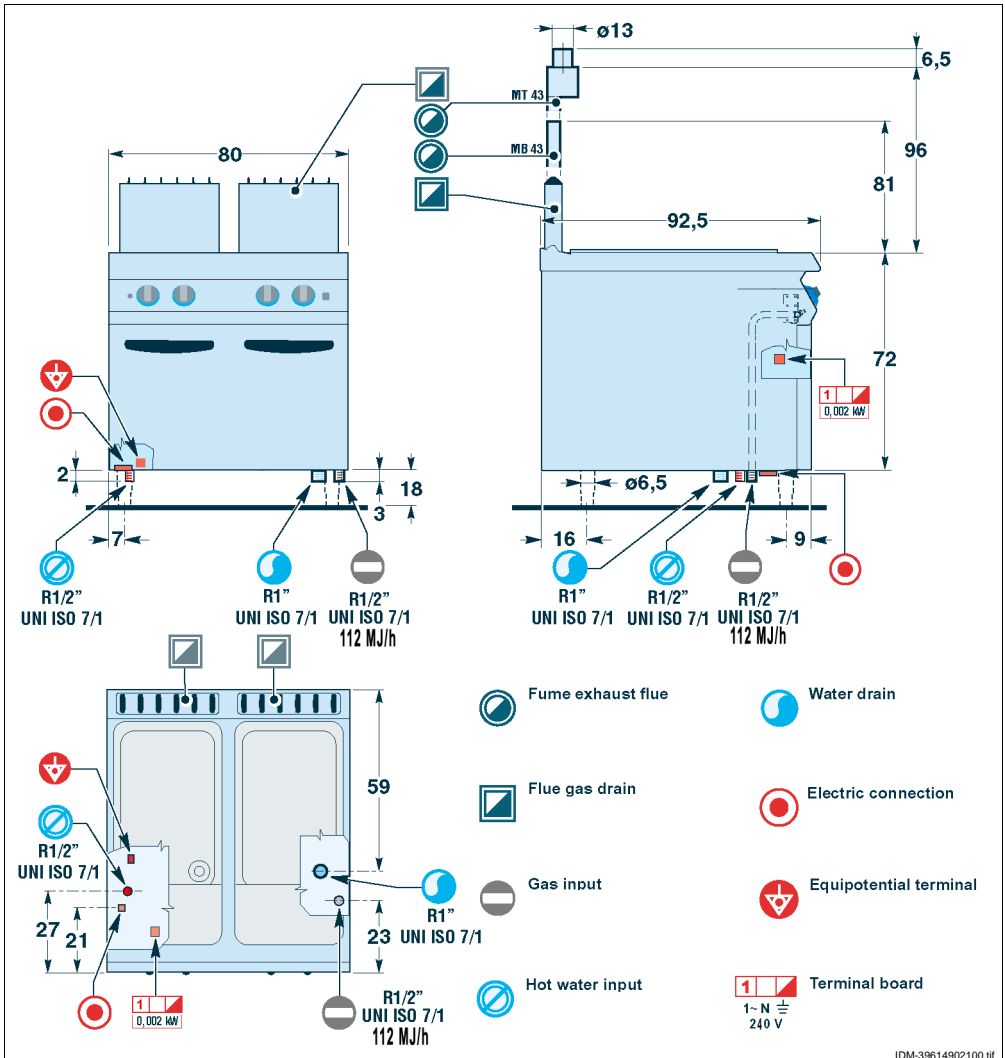

ELECTRICAL SYSTEM DIAGRAM (091CP1G)

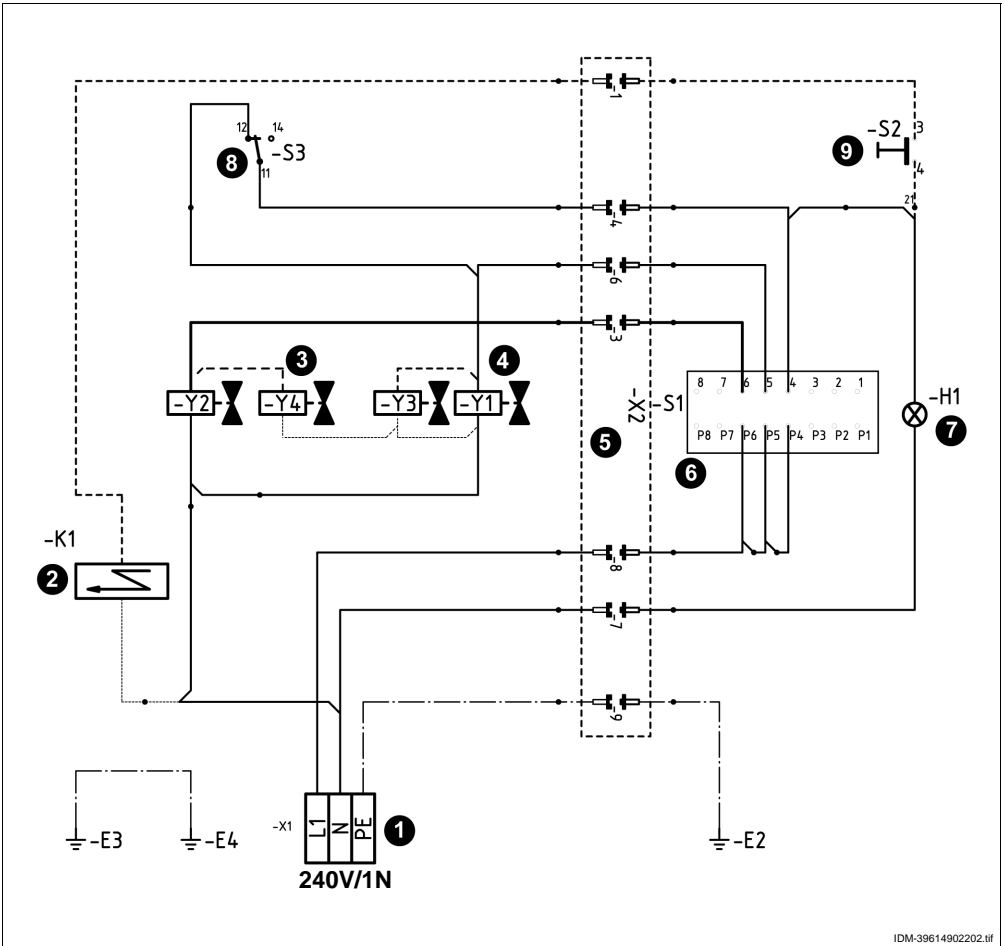

IDM-39614902202.tif

- | | |
|---|--|
| <p>1) Terminal board
 2) Igniter
 3) Water level maintenance solenoid valve
 4) Filler solenoid valve
 5) 9-pin connector</p> | <p>6) 4-setting switch
 7) Green light
 8) Water pressure switch
 9) Ignition button</p> |
|---|--|

ELECTRICAL SYSTEM DIAGRAM (191CP2G)

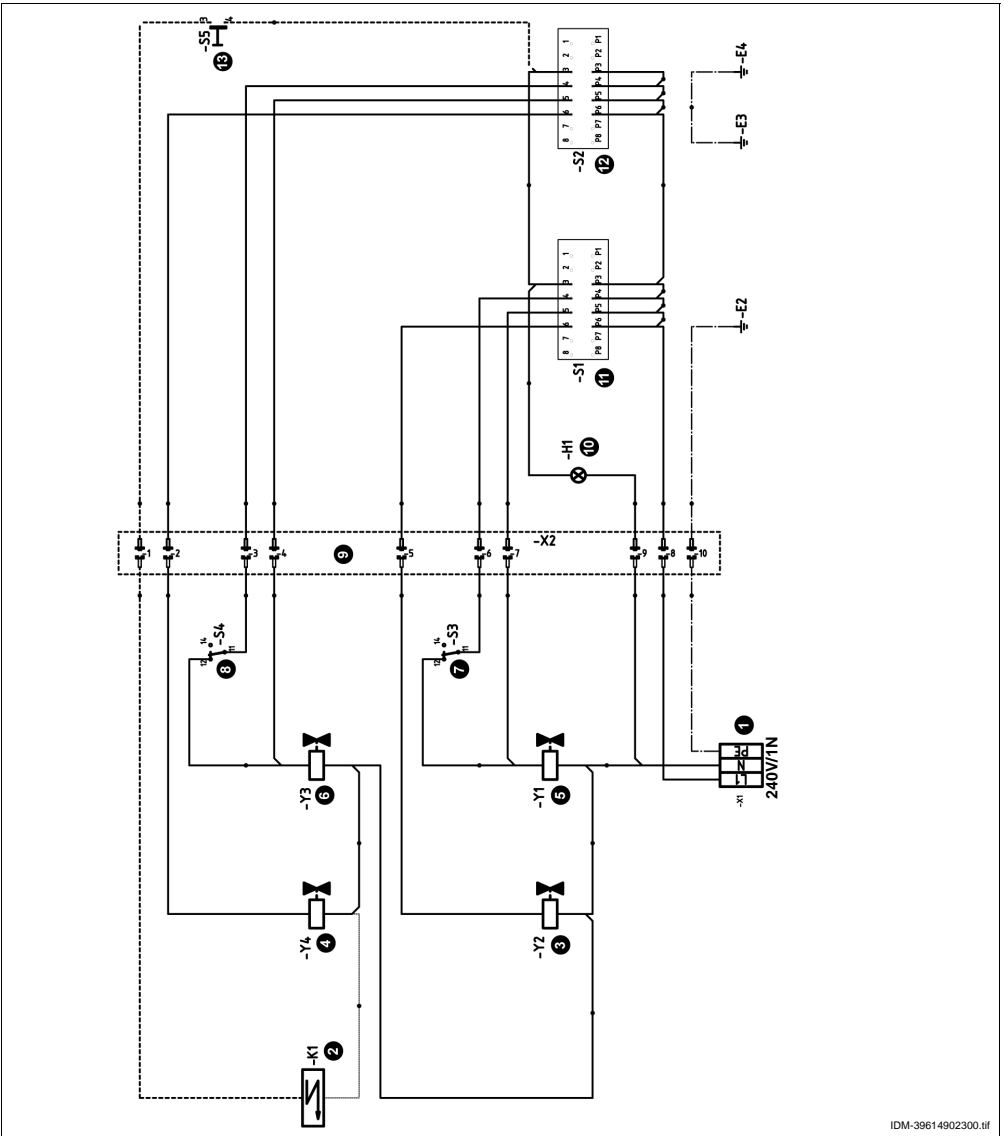

IDM-39614902300.tif

- | | |
|---|---|
| <ul style="list-style-type: none"> 1) Terminal board 2) Igniter 3) Left well water level maintenance solenoid valve 4) Left well filling solenoid valve 5) Right well water level maintenance solenoid valve 6) Right well filling solenoid valve | <ul style="list-style-type: none"> 7) Left well water pressure switch 8) Right well water pressure switch 9) 12-pin connector 10) Green light 11) 4 position switch, left well 12) 4 position switch, right well 13) Ignition button |
|---|---|

091CP1G

			N.G.C. (2)		T.G.C. (3)			Pilot flame	Iron Ring
GAS	TPP (1)	Supply pressure	G.C.	Ø (2.1)	G.C.	Ø (3.1)	p (3.2)	Ø (4)	Ø (5)
NGN	0.9 kPa	1.13 kPa	56 MJ/h	3.60 mm	26 MJ/h	1.45 mm	adj-pressure 0.15 kPa	0.40 mm	6 holes x5.5 mm adjusted to 26 mm
ULPG	2.65 kPa	2.75 kPa	56 MJ/h	2.05 mm	22 MJ/h	1.45 mm	fully tightened 0.40 kPa	0.25 mm	6 holes x5.5 mm adjusted to 21 mm

- (1) - Test point pressure on manifold
- (2) - Nominal gas consumption
- (2.1) - Main burner injector size
- (3) - Turndown gas consumption

- (3.1) - Bypass injector size
- (3.2) - Bypass test point pressure on outlet of gas valve
- (4) - Pilot injector size
- (5) - Iron Ring holes

191CP2G

			N.G.C. (2)		T.G.C. (3)			Pilot flame	Iron Ring
GAS	TPP (1)	Supply pressure	G.C.	Ø (2.1)	G.C.	Ø (3.1)	p (3.2)	Ø (4)	Ø (5)
NGN	0.9 kPa	1.13 kPa	112 MJ/h	3.60 mm	26 MJ/h	1.45 mm	adj-pressure 0.15 kPa	0.40 mm	6 holes x5.5 mm adjusted to 26 mm
ULPG	2.65 kPa	2.75 kPa	112 MJ/h	2.05 mm	22 MJ/h	1.45 mm	fully tightened 0.40 kPa	0.25 mm	6 holes x5.5 mm adjusted to 21 mm

- (1) - Test point pressure on manifold
- (2) - Nominal gas consumption
- (2.1) - Main burner injector size
- (3) - Turndown gas consumption

- (3.1) - Bypass injector size
- (3.2) - Bypass test point pressure on outlet of gas valve
- (4) - Pilot injector size
- (5) - Iron Ring holes