

**INSTALLAZIONE - USO**  
***INSTALLATION - OPERATION***  
**INSTALLATION - UTILISATION**  
***INSTALACION - UTILIZACION***  
**INSTALLATION - BEDIENUNG**

# **Kit**

# **LDR610**

**LANCIA A DOCCIA**  
***SPRAY GUN***  
**DOUCHE DE LAVAGE**  
***LANZADERA DE LIMPIADO***  
**HANDBRAUSE**

## INDICE

I.	COMPONENTI DEL KIT .....	1
II.	ISTRUZIONI PER L'INSTALLAZIONE .....	2 - 6

## TABLE OF CONTENTS

I.	COMPONENTS .....	1
II.	INSTRUCTIONS FOR THE INSTALLER .....	2 - 6

## INDEX

I.	COMPOSANTS DU KIT .....	1
II.	INSTRUCTIONS POUR L'INSTALLATION .....	2 - 6

## INDICE

I.	COMPONENTES DEL KIT .....	1
II.	INSTRUCCIONES PARA LA INSTALACION .....	2 - 6

## INHALTVERZEICHNIS

I.	BESTANDTEILE .....	1
II.	AUFSTELLUNGSANWEISUNG .....	2 - 6

# I.

## LANCIA A DOCCIA - SPRAY GUN - DOUCHE DE LAVAGE LANZADERA DE LIMPIADO - HANDBRAUSE

### COMPONENTI DEL KIT

- A** = Supporto anteriore della lancia (1/1)  
**B** = Doccia "Minireel"  
- B<sub>1</sub> = Lancia  
- B<sub>2</sub> = Viti  
- B<sub>3</sub> = Tubo flessibile da 1/2"  
**C** = Supporto posteriore 1/1  
**D** = Riduzione 3/4" - 1/2"  
**E** = Supporto posteriore (2/1)  
**F** = Raccordo a "T" da 3/4"  
**G** = Nipplo da 3/4"  
**H** = Supporto posteriore (1/1)  
**J** = Dadi M5x4  
**I** = Rosette Ø6  
**L** = Vite autofilettante  
**M** = Viti M5x12  
**N** = Raccordo 3/4"(2/1)  
**O** = Boccola lancia+viti M4x11

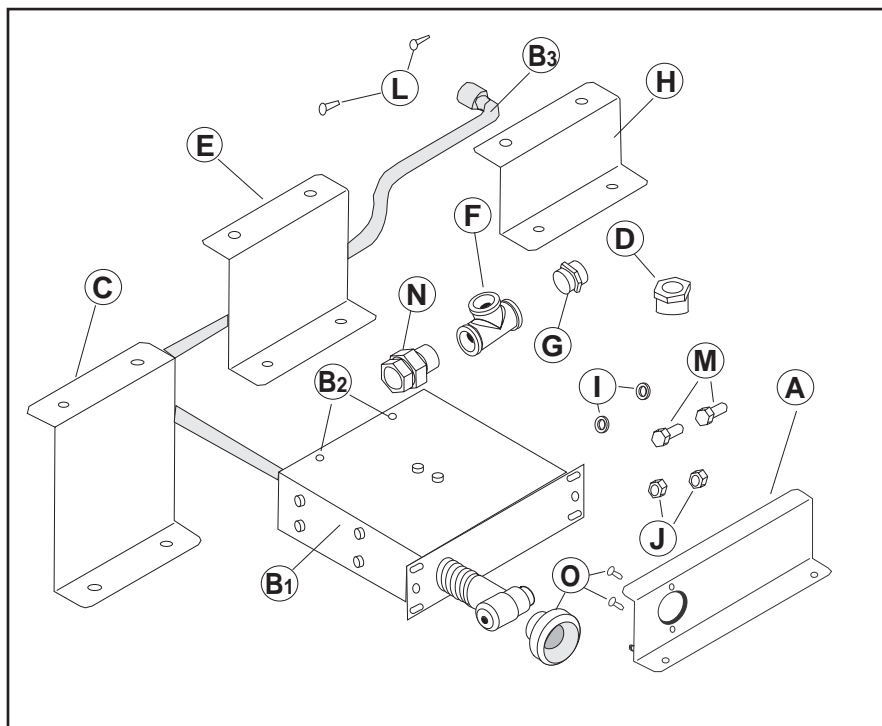

### COMPONENTS

- A** = Spray gun front support (1/1)  
**B** = Shower "Minireel"  
- B<sub>1</sub> = Spray gun  
- B<sub>2</sub> = Bolts  
- B<sub>3</sub> = Flexible pipe - 1/2"  
**C** = Rear support (1/1)  
**D** = Adapter 3/4" - 1/2"  
**E** = Rear support (2/1)  
**F** = Tee 3/4"  
**G** = Barrel nipple 3/4"  
**H** = Rear support (1/1)  
**J** = Nuts, M5x4  
**I** = Washers Ø6  
**L** = Self-tapping screw  
**M** = Bolts, M5x12  
**N** = Nipple M/F 3/4"(2/1)  
**O** = Spray gun bush + bolts M4x11

### COMPOSANTS DU KIT

- A** = Support avant douchette de nettoyage (1/1)  
**B** = Douche "Minireel"  
- B<sub>1</sub> = Douche de lavage  
- B<sub>2</sub> = Vis  
- B<sub>3</sub> = Tube flexible de 1/2"  
**C** = Support arrière (1/1)  
**D** = Réduction 3/4" - 1/2"  
**E** = Support arrière (1/1)  
**F** = Raccord "t" 3/4"  
**G** = Mamelon diable de 3/4"  
**H** = Support arrière (2/1)  
**J** = Ecrous, M5x4  
**I** = Rondelles Ø6  
**L** = Vis autotaraudeuses  
**M** = Vis, M5x12  
**N** = Raccord 3/4"(2/1)  
**O** = Bague douchette de nettoyage + Vis M4x11

### COMPONENTES DEL KIT

- A** = Soporte anterior de la ducha de lavado (1/1)  
**B** = Ducha "Minireel"  
- B<sub>1</sub> = Lanzadera a ducha  
- B<sub>2</sub> = Tornillos  
- B<sub>3</sub> = Tubo flexible de 1/2"  
**C** = Soporte posterior (1/1)  
**D** = Reducción 3/4" - 1/2"  
**E** = Soporte posterior (1/1)  
**F** = Raccor "t" de 3/4"  
**G** = Casquillo roscado doble de 3/4"  
**H** = Soporte posterior (2/1)  
**J** = Tuercas, M5x4  
**I** = Arandelas Ø6  
**L** = Tornillos autorroscantes  
**M** = Tornillos, M5x12  
**N** = Raccor de 3/4"(2/1)  
**O** = Casquillo de la ducha de lavado+Tornillos M4x11

### BESTANDTEILE

- A** = Vordere Brausenhalterung (1/1)  
**B** = Dusche "Minireel"  
- B<sub>1</sub> = Stützstift  
- B<sub>2</sub> = Schrauben  
- B<sub>3</sub> = Schlauch 1/2"  
**C** = Hintere Halterung (1/1)  
**D** = Stutzen 3/4" - 1/2"  
**E** = Hintere Halterung (1/1)  
**F** = T-Stück 3/4"  
**G** = Doppelnippel 3/4"  
**H** = Hintere Halterung (2/1)  
**J** = Muttern M5x4  
**I** = Unterlegscheiben Ø6  
**L** = Blechschrauben  
**M** = Schrauben M5x12  
**N** = Stück 3/4"(2/1)  
**O** = Brausenbuchse + Schrauben M4x11

# FM 611 (1-2) / FM 1011 (1-2)

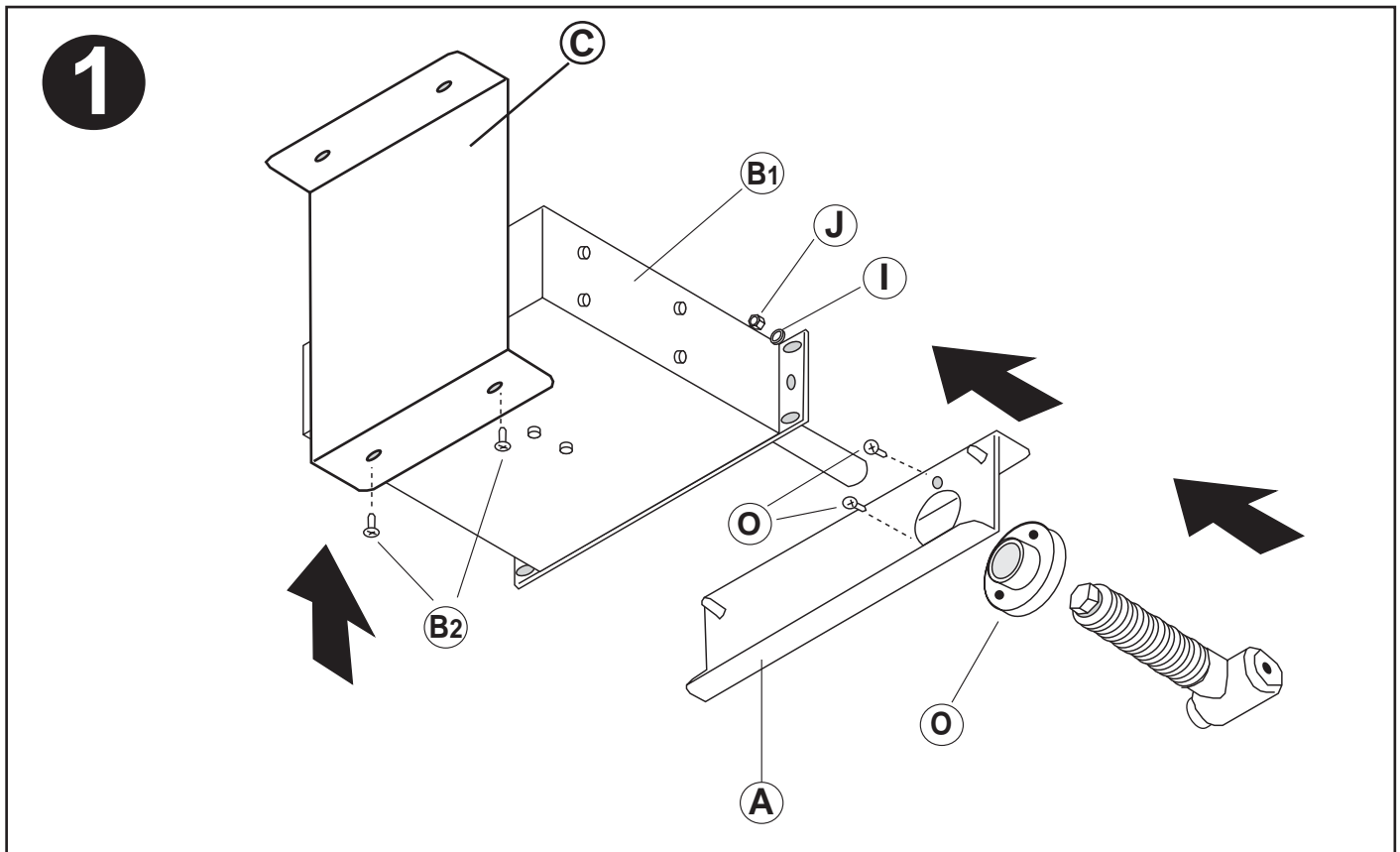

# FM 611 (3) / FM 1011 (3)

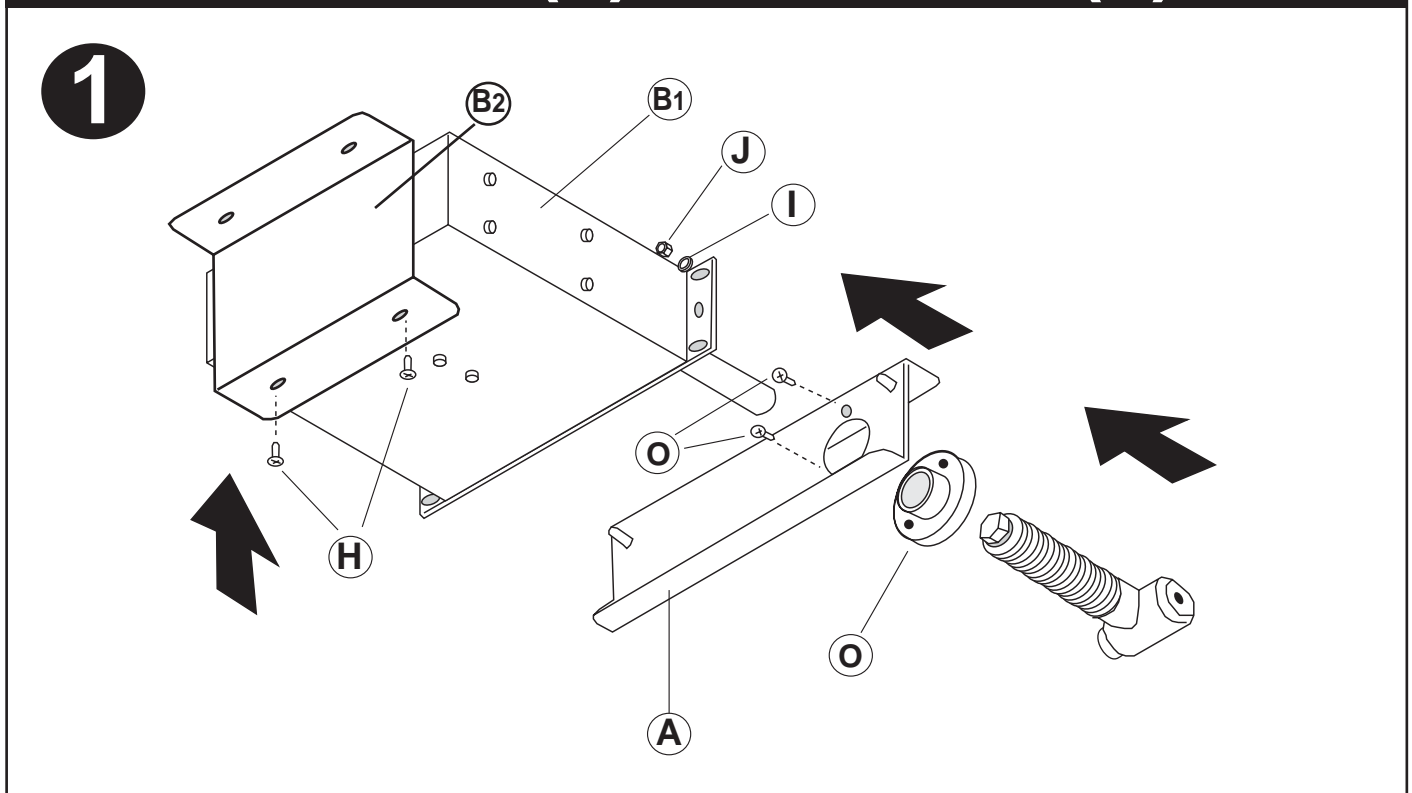

# FM 611 (1-2-3-) / FM 1011 (1-2-3-)

**2**

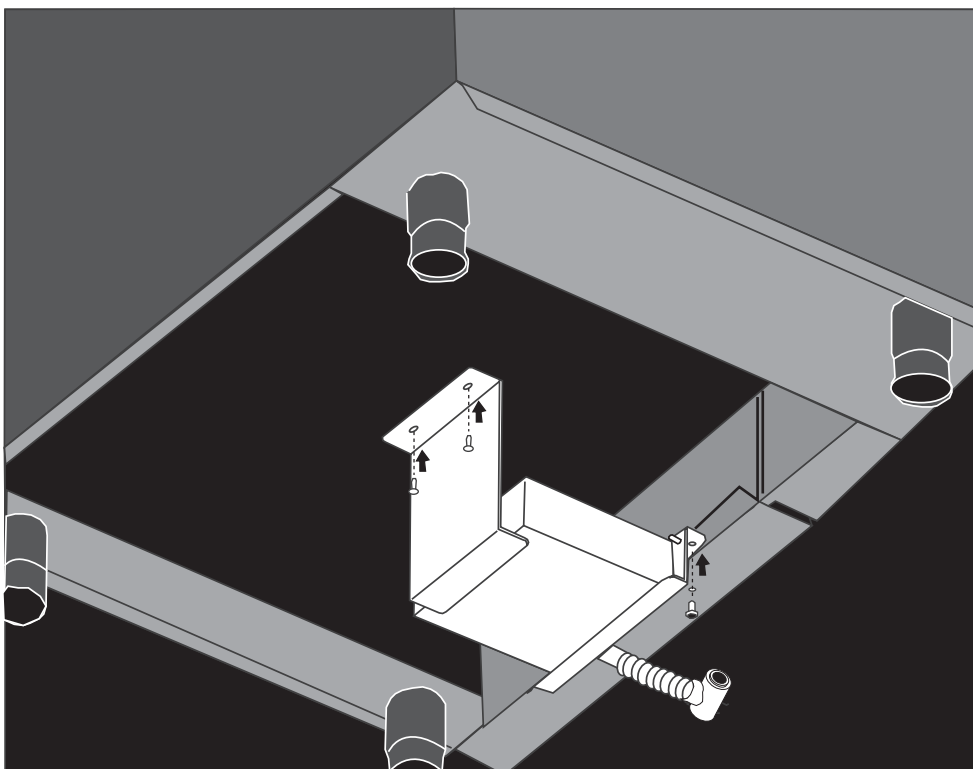
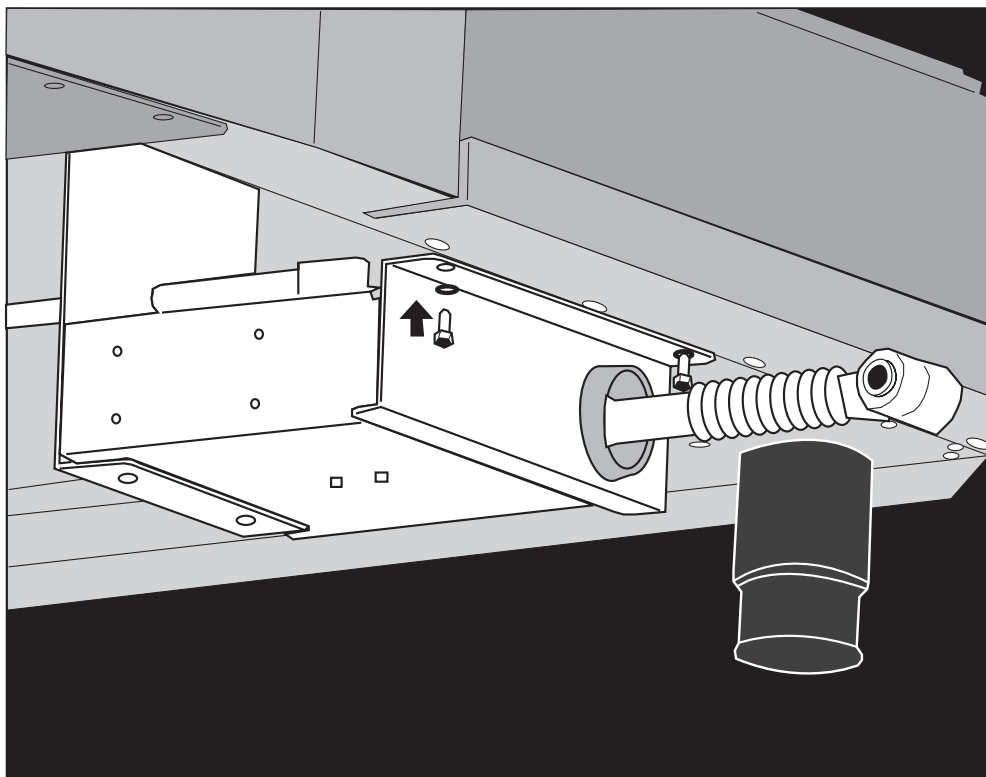

**II •** ISTRUZIONI DI DI MONTAGGIO - ASSEMBLING INSTRUCTIONS  
INSTRUCTIONS DE MONTAGE - FASE DE MONTAJE - ZUSAMMENBAU

**FM 721 / FM 1221 / FM2021 (1-2-3)**

**1**

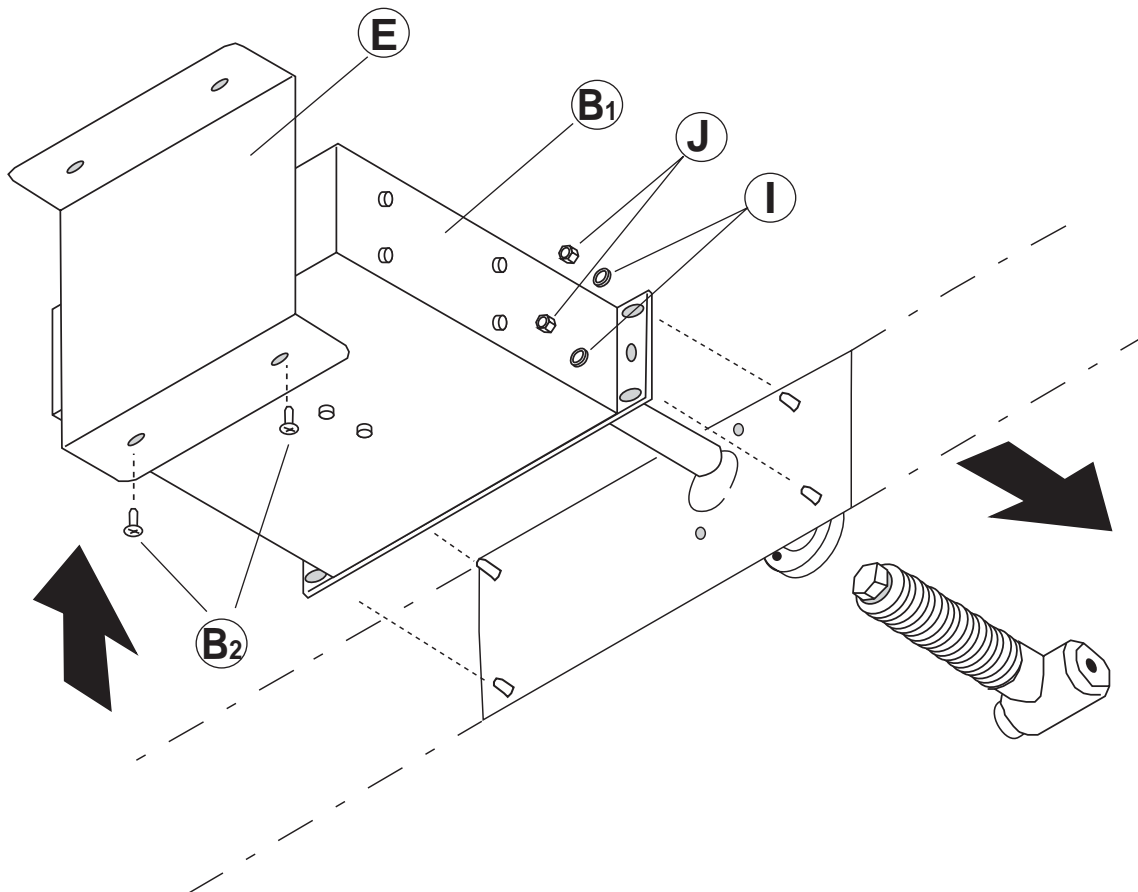

# II •

ISTRUZIONI DI DI MONTAGGIO - ASSEMBLING INSTRUCTIONS  
INSTRUCTIONS DE MONTAGE - FASE DE MONTAJE - ZUSAMMENBAU

## FM721 / FM1221 / FM2021 (1-2-3)

2

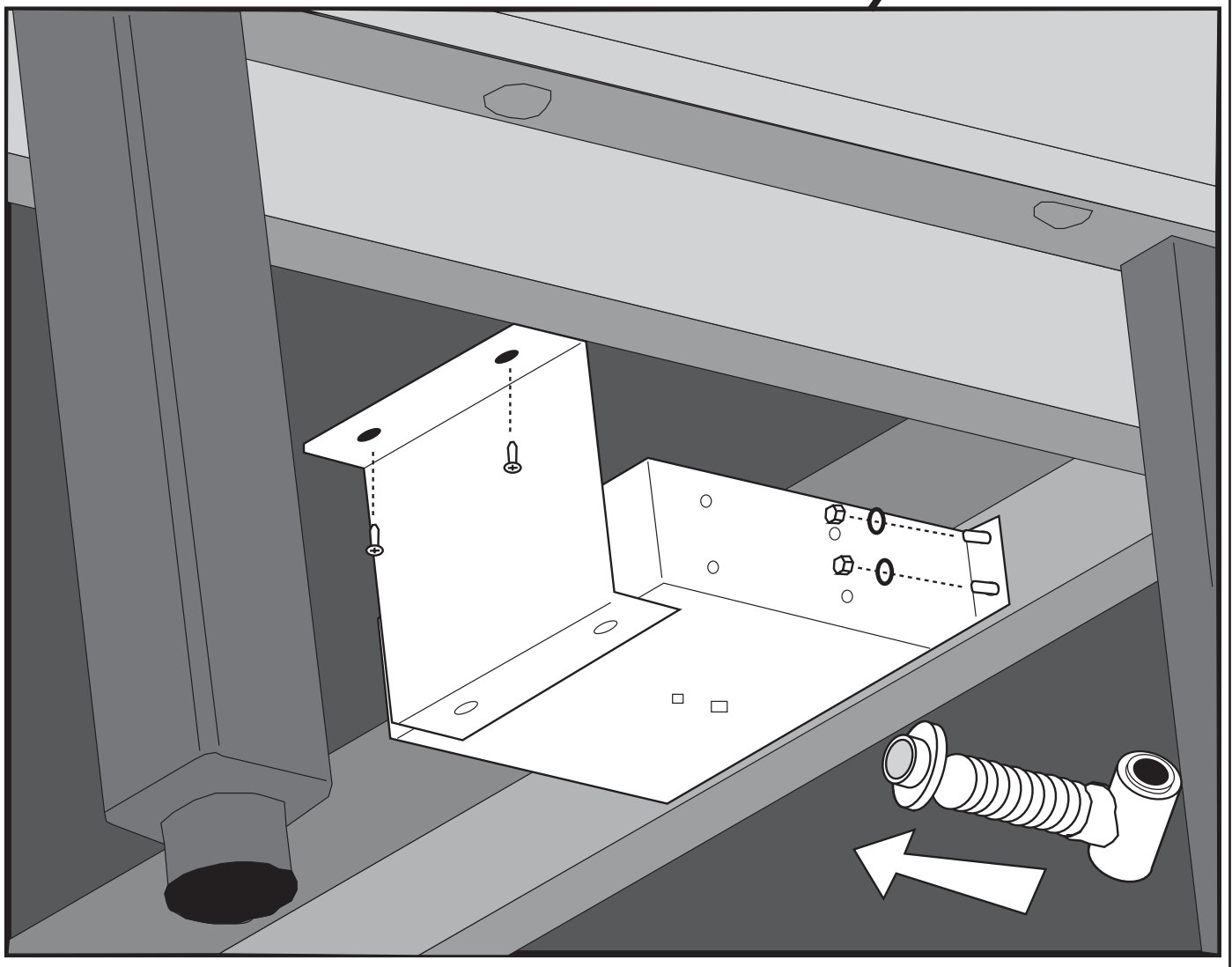
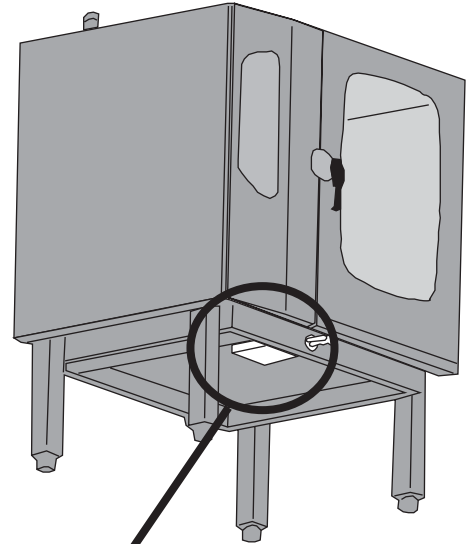

**ISTRUZIONI DI DI MONTAGGIO - ASSEMBLING INSTRUCTIONS  
INSTRUCTIONS DE MONTAGE - FASE DE MONTAJE - ZUSAMMENBAU**

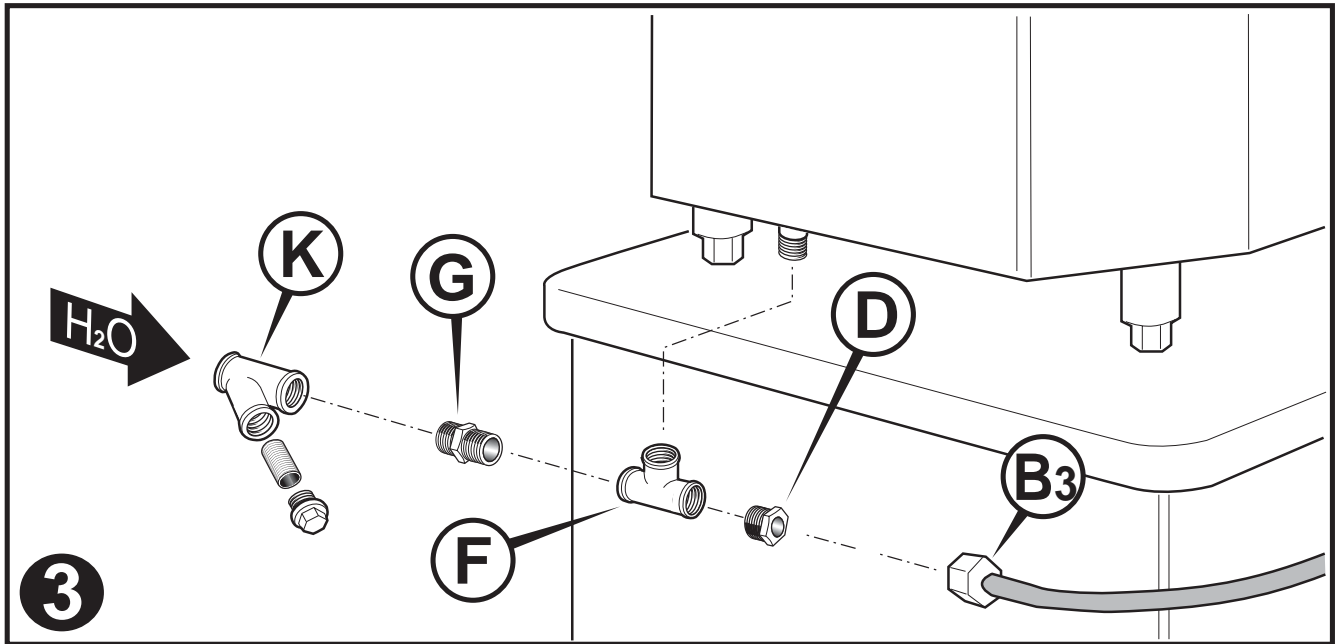

Modelli FM 611 - FM1011 installati su tavolo o altro mobile o forni sovrapposti  
*Models FM 611 - FM1011 placed on a table or on other cabinet or on other oven*  
 Modèles FM 611 - FM1011 placés sur une table ou autre meuble ou autre four  
 Modelos FM 611 - FM1011 sobre armario o mesa o un outro forno  
 Combi-Dämpfer FM 611 - FM1011 auf Schranktisch )

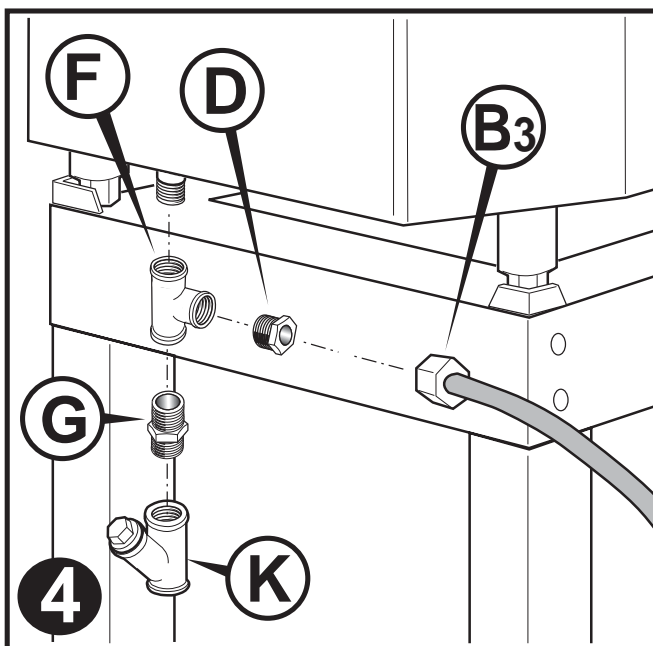

Modelli FM 611 - FM1011 su telaio  
*Models FM 611 - FM1011 placed on stand*  
 Modèles FM 611 - FM1011 placés sur tréteau  
 Modelos FM 611 - FM1011 sobre soporte  
 Combi-Dämpfer FM 611 - FM1011 auf Gestell

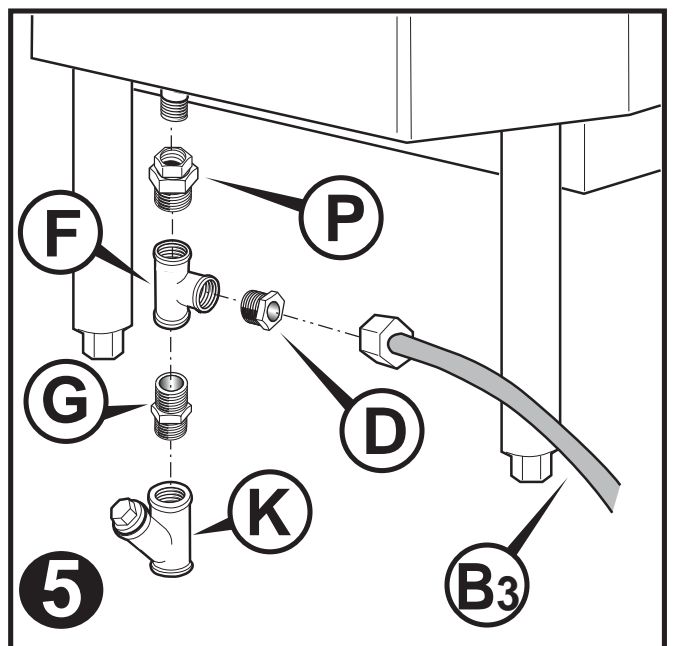

Modelli FM721 - FM1221 - FM2021  
*Models FM721 - FM1221 - FM2021*  
 Modèles FM721 - FM1221 - FM2021  
 Modelos FM721 - FM1221 - FM2021  
 Combi-Dämpfer FM721 - FM1221 - FM2021

**N.B.:** il filtro **K** viene fornito assieme al forno.  
**N.B.:** le filtre **K** est livré avec le four.  
**Vermerk:** Filter **K** ist jedem Combi-Dämpfer mitgeliefert.

**Note:** filter **K** is supplied together with the oven.  
**N.B.:** el filtro **K** es entregado con el horno.